

p-ISSN: 2615-6202

e-ISSN: 2615-6636



**AUTOMOTIVE  
EXPERIENCES**

Published by



LABORATORIUM OTOMOTIF  
Universitas Muhammadiyah Magelang



**AIVE**  
Association of Indonesian Vocational Educators

## About Journal

**Automotive Experiences (AE)** is a peer-reviewed journal published by Universitas Muhammadiyah Magelang in collaboration with Association of Indonesian Vocational Educators (AIVE). This scientific journal specifically addresses findings, new methods, and research experiences on automotive technology, science, and engineering. AE has been indexed in **Scopus** (<https://suggestor.step.scopus.com/progressTracker?trackingID=3E45ECBDF5C9442F>) and accredited by the Indonesian Ministry of Research Technology and ranked **Sinta 1** (<http://sinta.ristekbrin.go.id/journals/detail?id=5676>) (first grade) by Science and Technology Index. For more information, please read the Journal Description and sidebar menu.



## Journal Description

## Reviewer Board

---

The editor would like to thank reviewers who have contributed to improving the quality of articles in Automotive Experiences. They are (27):

---

Dr. Salih Ozer

 (<https://www.scopus.com/authid/detail.uri?authorId=55566641300>)

(<https://orcid.org/0000-0002-6968-8734>)  ([https://scholar.google.co.id/citations?](https://scholar.google.co.id/citations?hl=id&user=LifblUcAAAAJ)



[https://www.researchgate.net/profile/Salih\\_Oezer2](https://www.researchgate.net/profile/Salih_Oezer2)) 

Mus Alparslan University, Turkey

**Interest:** Renewable Energy Technologies; Engineering Thermodynamics; Automobile Engineering; Simulation; Thermal Engineering; Applied Thermodynamics; Combustion Analysis; Emission; Waste Heat Recovery; Biodiesel Production; NOX; Diesel Engines; Transesterification; Fuels



Gabriel Jeremy Gotama

 (<https://www.scopus.com/authid/detail.uri?authorId=57200700011>)  
(<https://orcid.org/0000-0003-0601-3630>)  (<https://scholar.google.co.id/citations?hl=id&user=-D04B1EAAAAAJ>)  ([https://www.researchgate.net/profile/Gabriel\\_Gotama](https://www.researchgate.net/profile/Gabriel_Gotama))





Nanyang Technological University, Singapore

Technical University of Munich, Germany

**Interest:** CFD; Combustion; Renewable Energy; Aerodynamic



Prof. Chih-Tsong Su (蘇啟宗)





 (<https://www.scopus.com/authid/detail.uri?authorId=7401682323>)   

National Kaohsiung University of Science and Technology, Taiwan

**Interest:** Precision Machining; High Speed Spindle; Vibration Test Analysis; Precision Mechanical Design; Ergonomics.



Dr. Riza Wirawan, MT.

 (<https://www.scopus.com/authid/detail.uri?authorId=57213421301>)  
(<https://orcid.org/0000-0002-3013-0784>)  (<https://scholar.google.co.id/citations?hl=id&user=Hcj4QiAAAAAJ>)  ([https://www.researchgate.net/profile/Riza\\_Wirawan](https://www.researchgate.net/profile/Riza_Wirawan))   
(<http://sinta.ristekbrin.go.id/authors/detail?id=5975692&view=overview>)

Bandung Institute of Technology, Indonesia

**Interest:** Material Characterization; Materials; Polymers; SEM Analysis; Polymeric Materials; Thermal Analysis; DSC; TGA; Thermal Properties; Thermogravimetric Analysis



Dr. Darwin Rio Budi Syaka, ST., MT.

 (<https://www.scopus.com/authid/detail.uri?authorId=53980675500>)  
(<https://scholar.google.co.id/citations?hl=id&user=ruVqW7AAAAAJ>)  
(<http://sinta2.ristekdikti.go.id/authors/detail?id=6124934&view=overview>)

Universitas Negeri Jakarta, Indonesia

**Interest:** Energy conversion; Engine performance; Refrigeration



**Thirunavukkarasu Raja, M.Eng**

 (<https://www.scopus.com/authid/detail.uri?authorId=57200271885>)

 (<https://orcid.org/0000-0001-9319-3005>)



(<https://scholar.google.co.id/citations?hl=id&user=uqQKrCQAAAAJ>)

 ([https://www.researchgate.net/profile/Thirunavukkarasu\\_R](https://www.researchgate.net/profile/Thirunavukkarasu_R))

([https://www.researchgate.net/profile/Thirunavukkarasu\\_R](https://www.researchgate.net/profile/Thirunavukkarasu_R))

Sri Ramakrishna Institute of Technology, India

**Interest:** Automobile Engineering; Thermal Engineering; Mechanical Engineering; Energy Conversion; Automotive Industry; Heat Exchangers; Applied Thermodynamics; Software Engineering; Combustion Analysis; Vehicle Testing; Emission; Renewable Energy and Environment Protection; Thermal Management; Biodiesel Production; Diesel Engines; Alternative Fuels



**Dr(c). Dwi Sudarno Putra, ST., MT.**

 (<https://www.scopus.com/authid/detail.uri?authorId=57190934927>)

 (<https://orcid.org/0000-0002-1209-8215>)



(<https://scholar.google.co.id/citations?hl=id&user=uCBe4E4AAAAJ>)

 (<http://sinta2.ristekdikti.go.id/authors/detail?id=5977820&view=overview>)

(<http://sinta2.ristekdikti.go.id/authors/detail?id=5977820&view=overview>)

Universitas Negeri Padang, Indonesia

**Interest:** Computational Intelligence; Automotive Engineering; Motor Control



**Prof. Dr. Eng. Azridjal Aziz, ST., MT.**

 (<https://www.scopus.com/authid/detail.uri?authorId=54959690800>)

 (<https://orcid.org/0000-0002-8601-7107>)



(<https://scholar.google.co.id/citations?hl=id&user=Zo5g6csAAAAJ>)

 (<http://sinta2.ristekdikti.go.id/authors/detail?id=25516&view=overview>)

(<http://sinta2.ristekdikti.go.id/authors/detail?id=25516&view=overview>)

Universitas Riau, Indonesia

**Interest:** Thermal engineering; Refrigeration and heat pump; Solar energy; Heating and cooling



**Wawan Purwanto, MT., Ph.D**

 (<https://www.scopus.com/authid/detail.uri?authorId=57190941721>)



(<https://orcid.org/0000-0002-8576-7264>)



(<https://scholar.google.co.id/citations?hl=id&user=V14GmzoAAAAJ>)



(<http://sinta2.ristekdikti.go.id/authors/detail?id=72697&view=overview>)

Universitas Negeri Padang, Indonesia

**Interest:** Automotive and electronic control



Dr(c). Anwar Ilmar Ramadhan, MT.

(<https://www.scopus.com/authid/detail.uri?authorId=57193457659>)

(<https://orcid.org/0000-0002-2443-0051>) (<https://scholar.google.co.id/citations?hl=id&user=Y5nDI6UAAAAJ>) ([https://www.researchgate.net/profile/Anwar\\_Ramadhan](https://www.researchgate.net/profile/Anwar_Ramadhan))

(<http://sinta2.ristekdikti.go.id/authors/detail?id=257453&view=overview>)

Universitas Muhammadiyah Jakarta, Indonesia

**Interest:** Thermofluid; Nanofluid; New and Renewable Energy

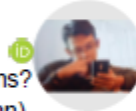

Mukhtar Hanafi, ST., M.Cs.

(<https://www.scopus.com/authid/detail.uri?authorId=57194771713>)

(<https://scholar.google.co.id/citations?hl=id&user=4U5slsQAAAAJ>)

([https://www.researchgate.net/profile/Mukhtar\\_Hanafi](https://www.researchgate.net/profile/Mukhtar_Hanafi))

(<http://sinta2.ristekdikti.go.id/authors/detail?id=5977366&view=overview>)

Universitas Muhammadiyah Magelang, Indonesia

**Interest:** Automotive mechatronics; Sensor; Actuator; Fuzzy Neural Network; Automatic Control System; Programming; Numerical Methods



Dr. Hendro Maxwell Sumual, M.Eng.

(<https://www.scopus.com/authid/detail.uri?authorId=57201075921>)

(<https://scholar.google.co.id/citations?hl=id&user=VevOHT8AAAAJ>)

(<http://sinta2.ristekdikti.go.id/authors/detail?id=6123593&view=overview>)

Universitas Negeri Manado, Indonesia

**Interest:** Composite, Automotive material, TVET



Gunawan Refiadi, ST., MT.

(<https://www.scopus.com/authid/detail.uri?authorId=57211093221>)

(<https://orcid.org/0000-0001-7726-2867>) ([https://scholar.google.co.id/citations?hl=id&user=Zh\\_dP5gAAAAJ](https://scholar.google.co.id/citations?hl=id&user=Zh_dP5gAAAAJ)) (<http://sinta2.ristekdikti.go.id/authors/detail?id=6034138&view=overview>)

STKIP Sebelas April, Indonesia

**Interest:** Composite, Automotive material, Welding, Metallurgy & Materials, Corrosion



Saifudin, ST., M.Eng.

(<https://www.scopus.com/authid/detail.uri?authorId=57193447744>)

(<https://scholar.google.co.id/citations?hl=id&user=w8J6N3IAAAAAJ>)

([https://www.researchgate.net/profile/Saifudin\\_Stmeng](https://www.researchgate.net/profile/Saifudin_Stmeng))

(<http://sinta2.ristekdikti.go.id/authors/detail?id=6604829&view=overview>)

Universitas Muhammadiyah Magelang, Indonesia

**Interest:** Mechanics; Material; Corrosion





## Articles

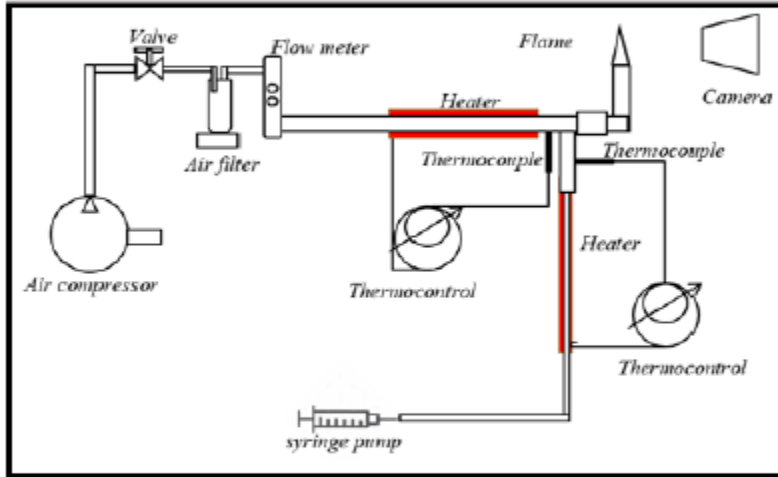

(<https://journal.unimma.ac.id/index.php/AutomotiveExperiences/article/view/4569>)

Experimental Study on the Effect of Nano Additives  $\gamma\text{Al}_2\text{O}_3$  and Equivalence Ratio to Bunsen Flame Characteristic of Biodiesel from Nyamplung (*Calophyllum Inophyllum*)

(<https://journal.unimma.ac.id/index.php/AutomotiveExperiences/article/view/4569>)

10.31603/ae.4569 (<https://journal.unimma.ac.id/index.php/AutomotiveExperiences/article/view/4569>)

51-61 Setyo Pambudi, Nasrul Ilminnafik, Salahuddin Junus, Muh Nurkoyim Kustanto

PDF (<https://journal.unimma.ac.id/index.php/AutomotiveExperiences/article/view/4569/2314>)

251

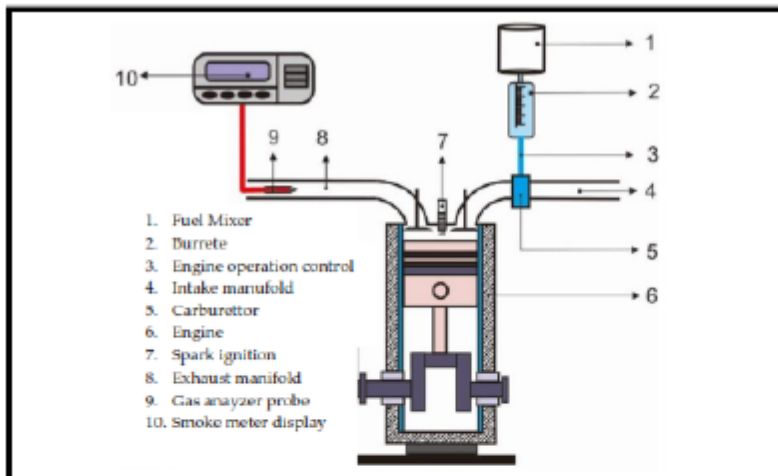

(<https://journal.unimma.ac.id/index.php/AutomotiveExperiences/article/view/4641>)

Effect Methanol, Ethanol, Butanol on the Emissions Characteristics of Gasoline Engine

(<https://journal.unimma.ac.id/index.php/AutomotiveExperiences/article/view/4641>)

10.31603/ae.4641 (<https://journal.unimma.ac.id/index.php/AutomotiveExperiences/article/view/4641>)

62-67

Syarifudin Syarifudin, Firman Lukman Sanjaya, Faqih Fatkhurrozak, M. Khumaidi Yohanes Sibagariang, Hasan Kötten

PDF (<https://journal.unimma.ac.id/index.php/AutomotiveExperiences/article/view/4641/2315>)

127

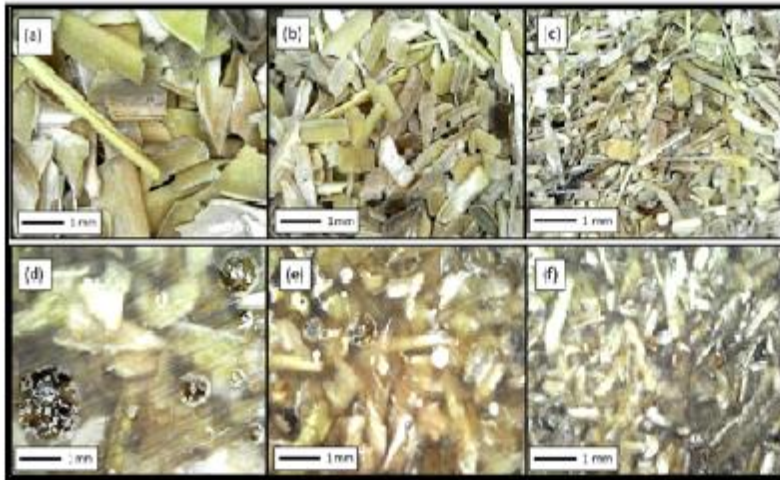

(<https://journal.unimma.ac.id/index.php/AutomotiveExperiences/article/view/4815>)

The Effects of Rice Husk Particles Size as A Reinforcement Component on Resin-Based Brake Pad Performance: From Literature Review on the Use of Agricultural Waste as A Reinforcement Material, Chemical Polymerization Reaction of Epoxy Resin, to Experiments

(<https://journal.unimma.ac.id/index.php/AutomotiveExperiences/article/view/4815>)

68-82

Asep Bayu Dani Nandiyanto, Siti Nur Hoffah, Gabriela Chelvina Santiuly Girsang, Silmi Ridwan Putri, Bentang Arief Budiman, Farid Triawan, Abdulkareem Sh. Mahdi Al-Obaidi

PDF (<https://journal.unimma.ac.id/index.php/AutomotiveExperiences/article/view/4815/2316>)

153

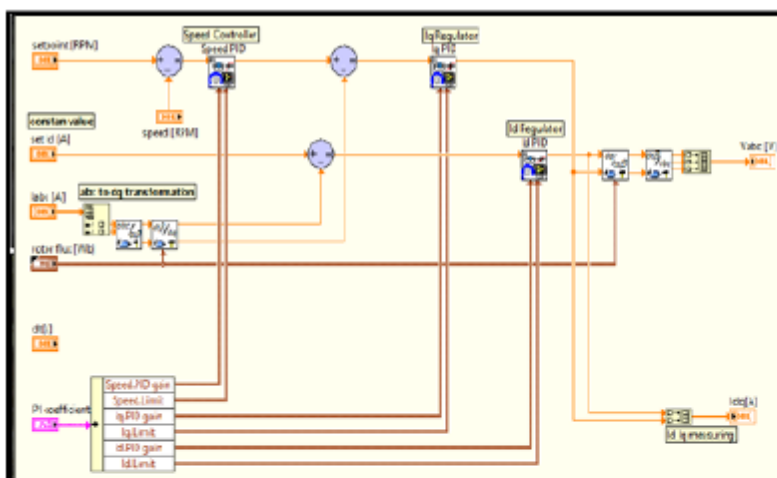

(<https://journal.unimma.ac.id/index.php/AutomotiveExperiences/article/view/4812>)

Static and Dynamic Performance of Vector Control on Induction Motor with PID Controller: An Investigation on LabVIEW

(<https://journal.unimma.ac.id/index.php/AutomotiveExperiences/article/view/4812>)

10.31603/ae.4812 (<https://journal.unimma.ac.id/index.php/AutomotiveExperiences/article/view/4812>)

83-96

Abdillah Aziz Muntashir, Era Purwanto, Bambang Sumantri, Hanif Hasyier FAKhrudin, Raden Akbar Nur Apriyanto

PDF (<https://journal.unimma.ac.id/index.php/AutomotiveExperiences/article/view/4812/2317>)

63



Research Paper

## Experimental Study on the Effect of Nano Additives $\gamma\text{Al}_2\text{O}_3$ and Equivalence Ratio to Bunsen Flame Characteristic of Biodiesel from Nyamplung (*Calophyllum Inophyllum*)

Setyo Pambudi , Nasrul Ilminnafik, Salahuddin Junus, Muh Nurkoyim Kustanto

Department of Mechanical Engineering, University of Jember, 68121, Indonesia

 [setyopmbd@gmail.com](mailto:setyopmbd@gmail.com)

 <https://doi.org/10.31603/ae.4569>



Published by Automotive Laboratory of Universitas Muhammadiyah Magelang collaboration with Association of Indonesian Vocational Educators (AIVE)

### Abstract

#### Article Info

Submitted:

02/02/2021

Revised:

13/03/2021

Accepted:

16/03/2021

Online first:

24/05/2021

Nano  $\gamma\text{Al}_2\text{O}_3$  is one of the nanometal oxides that has improved the characteristics of biodiesel. The effect of  $\gamma\text{Al}_2\text{O}_3$  nanoparticles on premixed flame combustion was investigated with an experiment on the laminar flame speed of *Calophyllum inophyllum* methyl ester 30% and 70% petrodiesel mixtures (CIME30), at atmospheric pressure and fixed preheating temperature  $T = 473\text{K}$ . The  $\gamma\text{Al}_2\text{O}_3$  nanoparticles added to CIME30 biodiesel were 0 ppm, 100 ppm, 200 ppm, and 300 ppm. Experiments were carried out on a bunsen burner. The equivalent ratio of the CIME30-air mixtures is between  $\phi = 0.67 - 1.17$ . Experiments revealed that the addition of nanoparticles to CIME30 biodiesel expands the flammability limit and increases the laminar flame speed. CIME30 without nanoparticles, flame was stable between  $\phi = 0,76 - 1,17$ . CIME30 with nanoparticles, flame was stable between  $\phi = 0,67 - 1,17$ . The highest laminar flame speed occurred at the equivalent ratio  $\phi = 0.83$ . The highest laminar flame speed of CIME30 0, 100, 200, and 300 ppm were 30.77, 34.50, 35.90, 38.45 cm/s respectively. The laminar flame speed was found to increase with the nano  $\gamma\text{Al}_2\text{O}_3$  concentration. This occurs due to the catalytic effect of  $\gamma\text{Al}_2\text{O}_3$  on biodiesel and its mixtures.

**Keywords:**  $\gamma\text{Al}_2\text{O}_3$ ; Bunsen burner; Equivalence ratio; Flame stability; Laminar flame speed

### Abstrak

Nano  $\gamma\text{Al}_2\text{O}_3$  merupakan salah satu oksida nanometal yang dapat meningkatkan karakteristik biodiesel. Pengaruh nanopartikel  $\gamma\text{Al}_2\text{O}_3$  pada pembakaran api premiks diselidiki dengan percobaan pada kecepatan api laminar campuran *Calophyllum inophyllum* metil ester 30% dan 70% petrodiesel (CIME30), pada tekanan atmosfer dan suhu pemanasan awal tetap  $T = 473\text{K}$ . Nanopartikel  $\gamma\text{Al}_2\text{O}_3$  yang ditambahkan ke biodiesel CIME30 adalah 0 ppm, 100 ppm, 200 ppm, dan 300 ppm. Percobaan dilakukan pada pembakar bunsen. Rasio ekuivalen campuran udara CIME30 adalah antara  $\phi = 0.67 - 1.17$ . Hasil eksperimen mengungkapkan bahwa penambahan nanopartikel ke biodiesel CIME30 memperluas batas mudah terbakar dan meningkatkan kecepatan nyala laminar. CIME30 tanpa nanopartikel nyala api stabil antara  $\phi = 0,76 - 1,17$ . CIME30 dengan nanopartikel, nyala api stabil antara  $\phi = 0,67 - 1,17$ . Kecepatan nyala api laminar tertinggi terjadi pada rasio ekuivalen  $\phi = 0.83$ . Kecepatan api laminar tertinggi CIME30 0, 100, 200, dan 300 ppm berturut-turut adalah 30.77, 34.50, 35.90, 38.45 cm s. Kecepatan api laminar ditemukan meningkat dengan konsentrasi nano  $\gamma\text{Al}_2\text{O}_3$ . Hal ini terjadi karena efek katalitik  $\gamma\text{Al}_2\text{O}_3$  pada biodiesel dan campurannya.

**Kata-kata kunci:**  $\gamma\text{Al}_2\text{O}_3$ ; Pembakar bunsen; Rasio ekuivalen; Stabilitas api; Kecepatan api laminar

## 1. Introduction

Alternative fuels need to reduce dependence on petroleum and it must be environmentally

friendly, cheap, technically acceptable, and abundant [1]. Biodiesel is an alternative fuel to replace petroleum diesel (petrodiesel). Biodiesel



This work is licensed under a Creative Commons Attribution-NonCommercial 4.0 International License.

has produced from plant oil or animal fat. Biodiesel is better than petrodiesel because of its low toxicity, renewable, and environmentally friendly properties [2]–[4]. Biodiesel in a diesel engine (compression-ignition engine) has reduced exhaust gas density but increase fuel consumption because the combustion heating value of biodiesel lower than petrodiesel [5], [6]. Biodiesel exhaust gas has contained more nitrogen oxides  $\text{NO}_x$ , but unburned hydrocarbons (HC), carbon monoxide (CO) are lower than petrodiesel [7]–[11]. Nano metal oxide additives have been used to improve the characteristics of biodiesel. Nano metal oxides are catalytic while a combustion reaction occurs in the combustion chamber and it increases combustion efficiency [12]–[14]. Nano metal oxides that have been researched as additives to biodiesel include  $\gamma\text{-Al}_2\text{O}_3$  [15],  $\text{CeO}_2$  [16],  $\text{TiO}_2$  [17],  $\text{ZnO}$  [10],  $\text{NiO}_2$  [18], Rhodium [19], and  $\text{SiO}_2$  [20].

Aluminum oxide, alumina ( $\text{Al}_2\text{O}_3$ ), is one of the most attractive ceramic materials for a wide variety of applications. Alumina ( $\text{Al}_2\text{O}_3$ ) has a phase transition  $\gamma$ ,  $\delta$ , and  $\theta$  before becoming the most stable ( $\alpha\text{-Al}_2\text{O}_3$ ) phase [21]. Nano  $\gamma\text{-Al}_2\text{O}_3$  is one of the nanometal oxides that has improved the characteristics of biodiesel. The heating value of jatropha biodiesel have been increased with the addition of the  $\gamma\text{-Al}_2\text{O}_3$  concentration. The thermal heating value of jatropha biodiesel without  $\gamma\text{-Al}_2\text{O}_3$  has 38.88 MJ/kg. Jatropha biodiesel with  $\gamma\text{-Al}_2\text{O}_3$  25 ppm has increased 1%, and 50 ppm has increased 2% from jatropha biodiesel without  $\gamma\text{-Al}_2\text{O}_3$  [22]. The cetane number and the calorific heating value also have increased in palm oil methyl ester (PME) as the increasing concentration of  $\gamma\text{-Al}_2\text{O}_3$ . The cetane number at PME 0 ppm has  $\text{CN} = 51$ . PME 25, 50, 75, and 100 ppm have increased cetane number to 55, 59, 62, 63 respectively. The heating value of PME 0 ppm has 38490 J/kg. PME 25, 50, 75, and 100 ppm have increased heating value to 38520 J/kg, 38560 J/kg, 38582 J/kg, 38590 J/kg respectively [23].

Laminar flame speed is the main parameter used for the design and optimization of internal combustion engines, gas turbines, and other combustion devices operating on premixed flames. The nanoparticles fuel mixture affects the speed of the laminar flame. The combustion of aluminum particles methane-air mixture causes the release of additional heat, which will most likely increase the rate of combustion [24]. The

laminar flame speed of butane-air has increased by 18.9% and 29.1% in terms of the addition of aluminum nanoparticles by 2 wt% and 5 wt%, respectively [25].

Surfactants are uses to increase the stability of the dispersion of nanoparticles biodiesel mixture. Cetyltrimethylammonium bromide (CTAB) is one of the examples of surfactant. CTAB has been used to stabilize  $\text{Al}_2\text{O}_3$  in palm oil biodiesel. CTAB has been added at 0.1 mg per liter of palm oil biodiesel. The  $\text{Al}_2\text{O}_3$  nanoparticles is stables the biodiesel for more than 96 hours [26]. Besides CTAB, span 80 and tween 80 with HLB 8 have been used to stabilize  $\text{Al}_2\text{O}_3$  nano particles to J20 biodiesel mixture [15]. The  $\text{Al}_2\text{O}_3$  nano particles are stables for 30 minutes to biodiesel in a long pipe. However, surfactants hurt the combustion. Surfactants reduces the droplet burning rate because a surfactant layer is formed around the primary droplets which inhibits air diffusion [27].

Bunsen burner is the most widely used tools for measuring laminar flame speed. Bunsen burner have a simple shape and good flame structure [28]. Several other studies on the speed of laminar flames using a bunsen burner have conducted by several researchers. By using a bunsen burner, kapok seed oil glycerol has been required a lot of air so that the highest laminar flame speed has occurred at an equivalent ratio of 0.36 [29]. Laminar flame speed for the diesel/air mixture and palm methyl ester (PME)/air at 470 K has around 86.7 and 86.5 cm/s at an equivalent ratio of 1.10 and 1.14 [30]. Also, by using  $\text{C}_3\text{H}_8/\text{O}_2/\text{CO}_2$  the laminar flame speed has increased with the addition of  $\text{O}_2$  concentration. Concentrations of  $\text{O}_2$  were added (28, 33, 36, and 40%), and the highest laminar flame speed have occurred at the equivalent ratio of 1.0 and 1.1 [31]. In addition to the fuel mixture and its equivalent ratio, preheating also affects the laminar flame speed. By using  $\text{CH}_4\text{-H}_2$ /air-fuel and a preheating temperature of 20 to 100 C, the laminar flame speed has increased with the addition of a given preheating temperature [32].

Therefore, this study aims to the effect of adding nano  $\gamma\text{-Al}_2\text{O}_3$  on the laminar flame speed of Nyamplung oil biodiesel (*Calophyllum inophyllum*). The combustion of biodiesel is carried out using a bunsen burner at an equivalent ratio of 0.67 to 1.17. The fuel used undergoes constant preheating and at atmospheric pressure.

2. Methods

2.1. Fuel preparation

Diesel fuel obtained from PT Pertamina Tanjung Wangi BBM terminal, supply, and distribution region V, Ketapang Banyuwangi, Indonesia. Biodiesel made from Nyamplung seed oil obtained from Nyamplung seed in Bondowoso, East Java, Indonesia. Nyamplung extracted mechanically. Biodiesel produced by esterification and transesterification of Nyamplung oil triglycerides.

Table 1 shows the specification of nano  $\gamma\text{Al}_2\text{O}_3$ . Nano  $\gamma\text{Al}_2\text{O}_3$  obtained from the Advanced Materials Laboratory, University of Jember. Nano  $\gamma\text{Al}_2\text{O}_3$  characterized using XRD. The average size of nano  $\gamma\text{Al}_2\text{O}_3$  is 26.37 nm with a gamma phase ( $\gamma$ ).

Table 1. Specification of nano  $\gamma\text{Al}_2\text{O}_3$

Manufacturer	: Jember university advanced materials laboratory
Particle colour	: White
Average size (TEM)	: 26.37 nm
Shape	: Spherical
Purity	: 82.5%
Phase	: $\Gamma$

2.2. Mixing

Calophyllum inophyllum methyl ester and petrodiesel was mixed in the ratio of 30:70 (CIME30).  $\gamma\text{Al}_2\text{O}_3$  nanoparticles and CIME30 was mixed using 40 kHz ultrasonic bath in 30 minutes [22]. To increase the stability of the mixture,

surfactant was added at a concentration of 1% v/v. The surfactant is span 80 and tween 80 with hydrophilic-lipophilic balance (HLB) = 8 [15]. The concentration of nanoparticles is 0, 100, 200, and 300 ppm. The ppm concentration calculated by mass. The nanoparticles biodiesel mixture observed for 24 hours to ensure stability. After ensuring that the mixture was stable, combustion and characterization tests are carried out.

2.3. Characterisation

Figure 1 shows the result of the CIME chromatography test. A chromatography test used to estimate the air-fuel ratio. The chromatography test was carried out at the Jember Polytechnic Bioscience Laboratory. The peaks and areas of 1 to 8 is indicates the percentage of molecules from Methyl laurate to Methyl arachistate. Table 2 shows the percentage of molecules composition of CIME from the chromatography test.

Table 2. Percentage of molecules composition of CIME from the chromatography test

No	Name of molecule	Molecular formula	(%)
1	Methyl laurate	$\text{C}_{15}\text{H}_{30}\text{O}_2$	0.62
2	Methyl myristate	$\text{C}_{15}\text{H}_{30}\text{O}_2$	2.97
3	Methyl arachidonate	$\text{C}_{22}\text{H}_{44}\text{O}_2$	1.44
4	Methyl palmitate	$\text{C}_{17}\text{H}_{34}\text{O}_2$	43.77
5	Methyl margarate	$\text{C}_{18}\text{H}_{36}\text{O}_2$	0.41
6	Methyl oleate	$\text{C}_{19}\text{H}_{36}\text{O}_2$	45.82
7	Methyl linoleate	$\text{C}_{19}\text{H}_{34}\text{O}_2$	2.25
8	Methyl arachistate	$\text{C}_{21}\text{H}_{42}\text{O}_2$	2.71

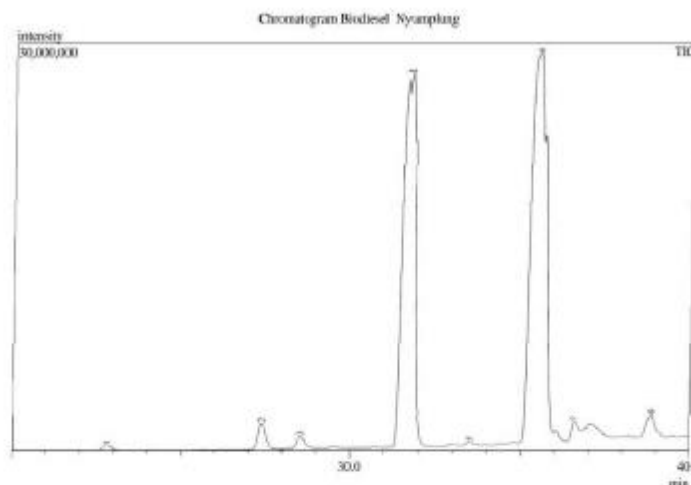

Figure 1. Chomatograph of CIME

Table 3 shows the physiochemical results test of biodiesel and mixtures. Physiochemical testing of CIME30 and mixture was carried out to determine the effect of adding nanoparticles on density, kinematic viscosity, flash point, and heating calorific value. The characteristics of CIME30 and mixture was tested in Sepuluh Nopember Institute of Technology, Surabaya.  $\gamma\text{Al}_2\text{O}_3$  nanoparticles affect the physiochemical of fuels. The addition of  $\gamma\text{Al}_2\text{O}_3$  nanoparticles decreased the viscosity of CIME [18], [23], [33] and low viscosity enhanced atomization of fuel [15]. The addition of nanoparticles also increased the heating calorific value of the combustion and flashpoint [34], [35]. The flashpoint decreased with the addition of the nanoparticles. This is also in line with Gad 2020 [15].

2.4. Experimental setup and procedure

Bunsen burner that made from stainless steel used to determine the premixed flame characteristics of the CIME30 and its mixtures. Figure 2 shows the schematic diagram of the experimental setup. Fuel flowed at a constant speed using a syringe pump. The fuel and air heated at 473 K at inner wall temperature of stainlesssteel pipe. The dimension of bunsen burner is 10 mm of inner diameter and 12 mm of outer diameter. The air flowed by a pressurized compressor and regulated using 0.5 LPM of airflow meter. The air varied from an equivalent ratio of 0.67 to 1.17. The Canon EOS m100 used to take videos. The video settings are 60 fps, shutter speed 1/1250, F6.3, and ISO 1250. Then, videos was converted into image using Image-J.

Table 3. Properties of fuel (CIME30)

Fuel	Density 15 °C (g/cm <sup>3</sup> ) ASTM-D1298	Kinematic viscosity 40 °C (CST) ASTM-D445	Flash point (°C) ASTM-D93	Calorific value (Kcal/Kg) ASTM-D240	Ref.
CIME 0 ppm	0.8558	5.5	101	10,295.00	Present study
CIME 100 ppm	0.8641	5	100	10,498.40	
CIME 200 ppm	0.8535	4.4	104	10,445.40	Krupakaran [18]
CIME 300 ppm	0.8553	3.6	97	10,571.00	
PMEA 10 ppm	-	4.8	130	-	
PMEA 125 ppm	-	4.76	160	-	
PMEA 50 ppm	-	4.74	168	-	
PMEA 175 ppm	-	4.73	172	-	Venu [23]
PMEA1 100 ppm	-	4.73	180	-	
Diesel	0.84	2.84	68	10,189.00	Venu [33]
BDE	0.8402	2.86	20	9,549.54	
BDE+AL	0.8372	2.57	22	9,356.31	Venu [33]
PBD	-	3.84	54 (D-976)	9,406.71	
PBD+25 Al <sub>2</sub> O <sub>3</sub>	-	3.92	55 (D-976)	9,492.93	
PBD+50 Al <sub>2</sub> O <sub>3</sub>	-	3.98	58 (D-976)	9,557.66	

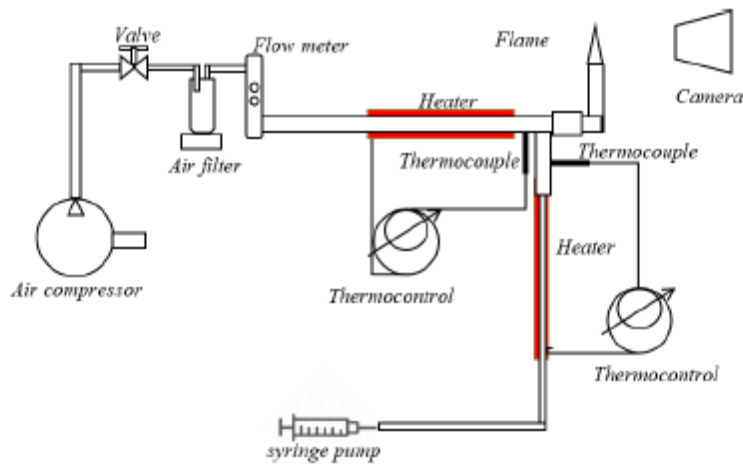

Figure 2. Schematic diagram of the test setup



Flame height and angle are primary data. Primary data converted into laminar flame speed data using Eq. (1) and Eq. (2). Then, Figure 3 shows the illustration of the cone bunsen flame angle.

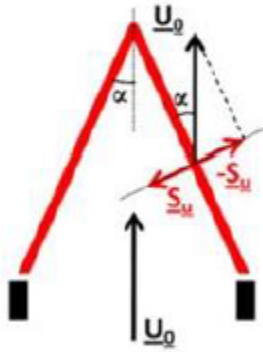

Figure 3. Illustration of cone bunsen flame angle [36]

The laminar flame speed is determined by Eq.(1):

$$SI = U_o \sin \alpha \quad (1)$$

With:

- SI = laminar flame speed (cm/s)
- U<sub>o</sub> = Speed of reactants (cm/s)
- α = half of the bunsen burner flame angle (°)

The speed of the reactants is determined by Eq.(2):

$$U_o = \frac{Q_{Fuel} + Q_{Air}}{A_b} \quad (2)$$

With:

- Q<sub>Fuel</sub> = fuel flow rate (cm<sup>3</sup>/s)
- Q<sub>Air</sub> = air flow rate (cm<sup>3</sup>/s)
- A<sub>b</sub> = burner cross-sectional area (cm<sup>2</sup>)

The experimental test was carried out from the equivalent ratio  $\phi = 0.67 - 1.17$ , where the equality ratio is defined in the Eq.(3).

$$\phi = \frac{(Q_{fuel}/Q_{air})_{actual}}{(Q_{fuel}/Q_{air})_{stoic}} \quad (3)$$

Finally, Figure 4 shows the image processing using the Image-J program. Figure 4a show the image from the camera (digital picture), Figure 4b shows the edges of flame from Image-J, and Figure 4c shows the measurement of angle from Image-J.

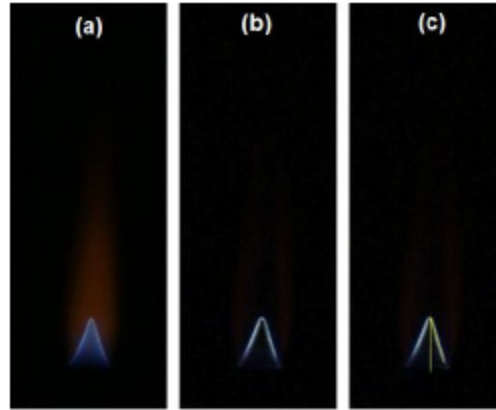

Figure 4. Method of image processing: (a). The image of bunsen flame, (b) Edges of bunsen flame, and (c) Measuring the cone angle of the flame

### 3. Result and Discussion

#### 3.1. Flame stability

Figure 5 shows the corresponding flame images of CIME30 0 ppm, 100 ppm, 200 ppm, and 300 ppm. The result show that the brighter the flame color was found to increase with the  $\gamma\text{Al}_2\text{O}_3$  concentration.

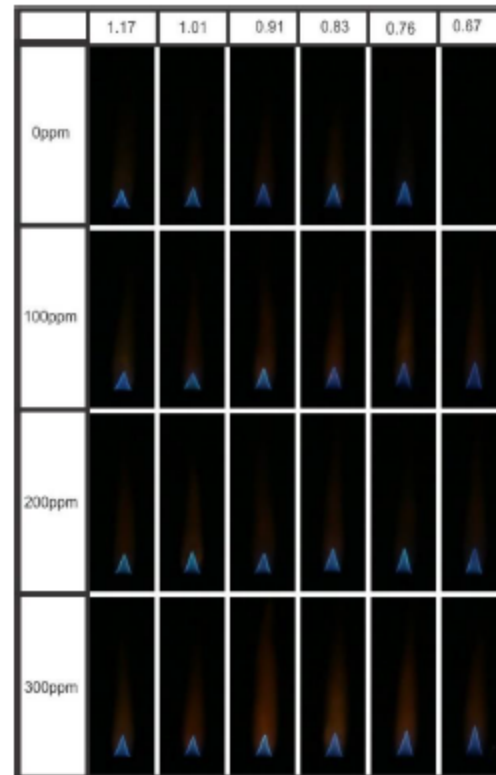

Figure 5. Photo of the experimental bunsen flame



The oxygen molecule broken down from  $\gamma\text{Al}_2\text{O}_3$  reacts with the fuel causing excess oxygen. oxygen molecules turn the flame brighter. this also occurs in the combustion of  $\text{C}_3\text{H}_8/\text{O}_2/\text{CO}_2$ . The higher the oxygen concentration had been the brighter the flame contour and the stronger the combustion reaction rate [31].

Figure 6 shows the flame stability map. The red solid triangle symbol is to indicates that there was a stable flame. The black solid triangle symbol is to indicates that there was a diffusion flame. The redline triangle symbol is to indicate that there was blow-off the flame.

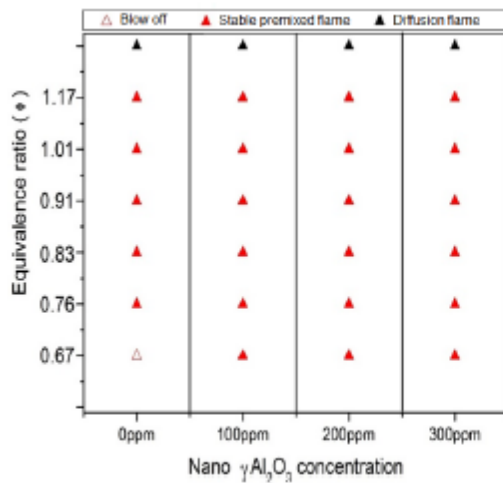

Figure 6. Flame stability map

Diffusion flame occurs due to excess fuel. Excess fuel reacts with the ambient air and produces a diffuse flame. The combustion of CIME30 biodiesel without the addition of nano  $\gamma\text{Al}_2\text{O}_3$  shows that the stable flame was occurred at an equivalent ratio of 0.76 to 1.17. CIME30 with the addition of nano  $\gamma\text{Al}_2\text{O}_3$  100, 200, and 300 ppm stable flame was occurred at an equivalence ratio of 0.67 to 1.17. This happened because of the catalytic effect from nano  $\gamma\text{Al}_2\text{O}_3$ . Catalysts have taken place in combustion under fuel-lean conditions [37].

### 3.2. Effect of nanoparticles on laminar flame speed

Figure 7 shows experimental of laminar flame speed biodiesel and mixture. Then, Figure 8 shows a comparison of present study's laminar flame speed with previous studies. Experiments indicate that laminar flame speed increased and decreased

with increasing equivalence ratio. The trend is the same with other hydrocarbon combustion research as petrodiesel, palm oil methyl ester,  $\text{CH}_4$ , and ethyl-benzene [30]. The highest laminar flame speed occurred at the equivalent ratio of 0.83. The highest laminar flame speed of CIME30 0, 100, 200, and 300 ppm were  $30.77 \pm 2\%$ ,  $34.50 \pm 3\%$ ,  $35.90 \pm 3\%$ ,  $38.45 \pm 2\%$  cm/s respectively. This research is in line with the Combustion of Kapok (*Ceiba pentandra*) seed oil research on Perforated Burner. Combustion of *Ceiba pentandra* seed oil has required a lot of air so that the highest flame speed occurs at an equivalent ratio of  $< 1$  (fuel-lean) conditions [29].

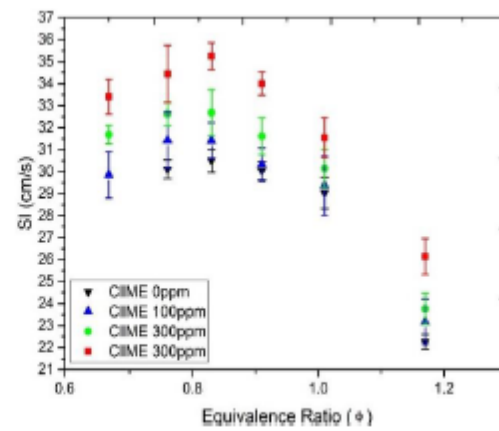

Figure 7. Laminar flame speed of biodiesel and mixture

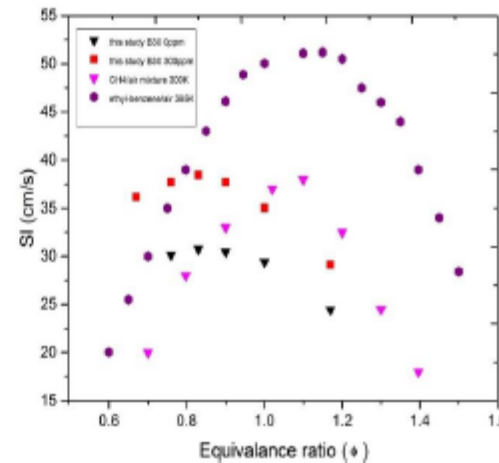

Figure 8. Comparison of laminar flame speeds

The laminar flame speed measurement of ethyl-benzene/air is higher than our measurement but has the same trend. This happens because the

heating temperature of ethyl-benzene/air is greater than in our study. The higher the preheating temperature, the higher the laminar flame speed [38]. Ethyl-benzenes is one of the alkylbenzenes molecules aromatic class found in diesel fuel [39]. Ethyl-benzene/air has a peak laminar flame speed which tends to be rich in fuel. CH<sub>4</sub>/air mixture laminar flame speed 300 K has a laminar flame speed peak that is almost the same as our research CIME30 300 ppm, but a different equivalent ratio.

γ-Al<sub>2</sub>O<sub>3</sub> has catalytic properties. This statement is also reinforced by the results of fuel characterization. The higher the concentration of nano alumina has added to biodiesel the higher the calorific heating value of the combustion. γ-Al<sub>2</sub>O<sub>3</sub> are nanoparticles that have high purity and excellent dispersion and high specific surface, with resistance to high temperatures and inert, and high activity [40]. Figure 9 shows a graph of laminar flame speed vs the concentration of γ-Al<sub>2</sub>O<sub>3</sub> in part per million (ppm). γ-Al<sub>2</sub>O<sub>3</sub> has affected the laminar flame speed of biodiesel. Experiments show that laminar flame speed has increased with the increase of nano γ-Al<sub>2</sub>O<sub>3</sub> concentration.

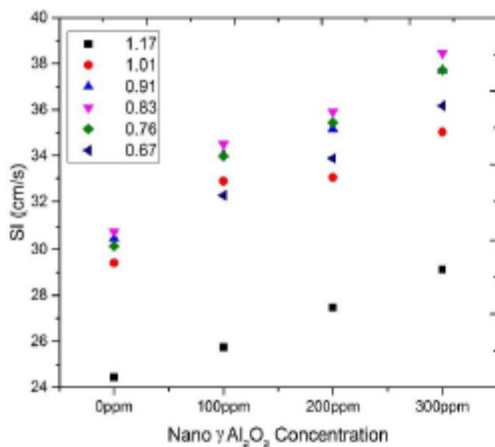

Figure 9. SI vs γ-Al<sub>2</sub>O<sub>3</sub> nano particles concentration

The CIME30 laminar flame speed increased by 3%, 6%, and 14% on average with the addition of γ-Al<sub>2</sub>O<sub>3</sub> of 100, 200, 300 ppm, respectively across all equivalent ratios. Equivalent ratio 0.83, the laminar flame speed increased by 3%, 7%, 16% with addition of a<sub>2</sub>o<sub>3</sub> 100, 200, 300ppm respectively. This is in line with Huang's study [41] which states that the increase in the

percentage of nanoparticles within the mixture enhanced its flame speed. Flame speed of laminar butane-air increases by 18.9% and 29.1% in terms of the addition of aluminum nanoparticles by 2 wt% and 5 wt%, respectively [25]. The flame speed will likely increase due to the release of heat energy from the aluminum nanoparticles [42]. Moreover, low viscosity enhanced atomization of fuel. higher atomization rate resulted in a better air-fuel mixture for complete combustion [12], [15].

γ-Al<sub>2</sub>O<sub>3</sub> also shows catalytic properties in diesel engine combustion. characteristics of fuel and combustion were increase indicated by adding nanoparticles [15]. The nano-sized particles have a reactive surface that aids reactivity as a potential catalyst. The nanoparticles in the biodiesel blends increase the surface area to volume ratio for better catalytic effect and better combustion. The combustion of nanoparticles occurs in two stages. In the first stage (primary stage), nano additives tend to mix with biodiesel as a binding mechanism and their chemical structures tend to break so that they accelerate the reaction.



In the second stage (secondary stage) the oxygen molecules present in the γ-Al<sub>2</sub>O<sub>3</sub> structure are liberated. This liberated oxygen together with higher heat reacts with unburned hydrocarbons and thereby increases the rate of combustion [26].

#### 4. Conclusion

The main objective of this study was to determine the effect of γ-Al<sub>2</sub>O<sub>3</sub> concentration and its equivalent ratio on the laminar flame speed of calophyllum inophyllum methyl ester 30% (CIME30). Laminar flame speeds were investigated using a bunsen burner at a fixed temperature and atmospheric pressure. γ-Al<sub>2</sub>O<sub>3</sub> was chosen because it can improve the characteristics of biodiesel according to previous studies. It also happens in our research that γ-Al<sub>2</sub>O<sub>3</sub> increased the heating calorific value of combustion up to 10,571.0 kcal/kg, and reduced the viscosity up to 3.6 cSt. The equivalent ratio (φ) was 0.67 until 1.7. The concentrations of γ-Al<sub>2</sub>O<sub>3</sub> added were 100, 200, and 300 ppm. The highest

laminar flame speed of CIME30 and its mixture has occurred at  $\phi = 0.83$ . The laminar flame speed increased by 3%, 7%, 16% at CIME30 100, 200, and 300 ppm, respectively. In addition to the laminar flame speed, the flame stability of CIME30 with  $\gamma\text{Al}_2\text{O}_3$  was increased. CIME30 with nano  $\gamma\text{Al}_2\text{O}_3$  100, 200, and 300 ppm, flame was stable at an equivalent ratio  $\phi = 0.67$ . However, the CIME30 without the nano  $\gamma\text{Al}_2\text{O}_3$ , the flame was left off at an equivalent ratio  $\phi = 0.67$ . This occurs due to the catalytic effect of  $\gamma\text{Al}_2\text{O}_3$  on biodiesel and its mixtures.

### Acknowledgement

The author would like to thank PT. Pertamina Tanjung Wangi, Jember University Advanced Materials Laboratory, Jember Polytechnic Bioscience Laboratory, and Water and Technology Laboratory and Chemical Engineering Industry Collaboration - Sepuluh

Nopember Institute of Technology, Surabaya which have helped provide materials, characterize, and help a lot in our research.

### Author's Declaration

#### Authors' contributions and responsibilities

The authors made substantial contributions to the conception and design of the study. The authors took responsibility for data analysis, interpretation and discussion of results. The authors read and approved the final manuscript.

#### Funding

No funding information from the authors.

#### Availability of data and materials

All data are available from the authors.

#### Competing interests

The authors declare no competing interest.

#### Additional information

No additional information from the authors.

### Nomenclature

$\phi$	:	Mixture equivalence ratio
BDE	:	Mixture of biodiesel (20%), diesel (70%), and ethanol (10%)
BDE+AL	:	Mixture of biodiesel (20%), diesel (70%), and ethanol (10%), $\text{Al}_2\text{O}_3$ 25ppm
CIME	:	<i>Calophyllum inophyllum</i> methyl ester
CIME30	:	Mixture of <i>calophyllum inophyllum</i> methyl ester 30% and petrodiesel 70%
CIME 0 ppm	:	Mixture of <i>calophyllum inophyllum</i> methyl ester 30% and petrodiesel 70%
CIME 100 ppm	:	Mixture of <i>calophyllum inophyllum</i> methyl ester 30% and petrodiesel 70% $\gamma\text{Al}_2\text{O}_3$ 100ppm
CIME 200 ppm	:	Mixture of <i>calophyllum inophyllum</i> methyl ester 30% and petrodiesel 70% $\gamma\text{Al}_2\text{O}_3$ 200ppm
CIME 300 ppm	:	Mixture of <i>calophyllum inophyllum</i> methyl ester 30% and petrodiesel 70% $\gamma\text{Al}_2\text{O}_3$ 300ppm
CTAB	:	Cetyltrimethylammonium bromide
PMEA1	:	Palm oil methyl ester biodiesel + $\gamma\text{Al}_2\text{O}_3$
J20	:	Jatropha biodiesel 20% + petrodiesel 80%
HLB	:	Hydrophilic-lipophilic balance
PBD	:	Polanga biodiesel
PBD+25 $\text{Al}_2\text{O}_3$	:	Mixture of polanga biodiesel + 25 ppm $\text{Al}_2\text{O}_3$
PBD+50 $\text{Al}_2\text{O}_3$	:	Mixture of polanga biodiesel + 50ppm $\text{Al}_2\text{O}_3$
PME	:	Palm oil methyl ester
SI	:	laminar flame speed (cm/s)
TEM	:	Scanning electron microscope
XRD	:	X-ray diffraction



## References

- [1] A. Arumugam and V. Ponnusami, "Biodiesel production from Calophyllum inophyllum oil a potential non-edible feedstock: An overview," *Renewable Energy*, vol. 131, pp. 459–471, 2019, doi: 10.1016/j.renene.2018.07.059.
- [2] E. Marlina, M. Basjir, M. Ichiyanagi, T. Suzuki, G. J. Gotama, and W. Anggono, "The Role of Eucalyptus Oil in Crude Palm Oil As Biodiesel Fuel," *Automotive Experiences*, vol. 3, no. 1, pp. 33–38, 2020.
- [3] D. Ayu, R. Aulyana, E. W. Astuti, K. Kusmiyati, and N. Hidayati, "Catalytic Transesterification of Used Cooking Oil to Biodiesel: Effect of Oil-Methanol Molar Ratio and Reaction Time," *Automotive Experiences*, vol. 2, no. 3, pp. 73–77, 2019.
- [4] S. Rezanía et al., "Review on transesterification of non-edible sources for biodiesel production with a focus on economic aspects, fuel properties and by-product applications," *Energy Conversion and Management*, vol. 201, no. July, p. 112155, 2019, doi: 10.1016/j.enconman.2019.112155.
- [5] S. M. A. Rahman, H. H. Masjuki, M. A. Kalam, M. J. Abedin, A. Sanjid, and H. Sajjad, "Production of palm and Calophyllum inophyllum based biodiesel and investigation of blend performance and exhaust emission in an unmodified diesel engine at high idling conditions," *Energy Conversion and Management*, vol. 76, pp. 362–367, 2013, doi: 10.1016/j.enconman.2013.07.061.
- [6] A. C. Arifin, A. Aminudin, and R. M. Putra, "Diesel-Biodiesel Blend on Engine Performance: An Experimental Study," *Automotive Experiences*, vol. 2, no. 3, pp. 91–96, 2019, doi: 10.31603/ae.v2i3.2995.
- [7] B. S. Chauhan, N. Kumar, and H. M. Cho, "A study on the performance and emission of a diesel engine fueled with Jatropha biodiesel oil and its blends," *Energy*, vol. 37, no. 1, pp. 616–622, 2012, doi: 10.1016/j.energy.2011.10.043.
- [8] H. Raheman and S. V. Ghadge, "Performance of compression ignition engine with mahua (*Madhuca indica*) biodiesel," *Fuel*, vol. 86, pp. 2568–2573, 2007, doi: 10.1016/j.fuel.2007.02.019.
- [9] A. Dhar, R. Kevin, and A. Kumar, "Production of biodiesel from high-FFA neem oil and its performance, emission and combustion characterization in a single cylinder DIC engine," *Fuel Processing Technology*, vol. 97, pp. 118–129, 2012, doi: 10.1016/j.fuproc.2012.01.012.
- [10] K. Nanthagopal, B. Ashok, A. Tamilarasu, A. Johny, and A. Mohan, "Influence on the effect of zinc oxide and titanium dioxide nanoparticles as an additive with Calophyllum inophyllum methyl ester in a CI engine," *Energy Conversion and Management*, vol. 146, pp. 8–19, 2017, doi: 10.1016/j.enconman.2017.05.021.
- [11] H. G. How, H. H. Masjuki, M. A. Kalam, Y. H. Teoh, and H. G. Chuah, "Effect of Calophyllum Inophyllum biodiesel-diesel blends on combustion, performance, exhaust particulate matter and gaseous emissions in a multi-cylinder diesel engine," *Fuel*, vol. 227, no. October 2017, pp. 154–164, 2018, doi: 10.1016/j.fuel.2018.04.075.
- [12] M. Annamalai et al., "An assessment on performance, combustion and emission behavior of a diesel engine powered by ceria nanoparticle blended emulsified biofuel," *Energy Conversion and Management*, vol. 123, pp. 372–380, 2016, doi: 10.1016/j.enconman.2016.06.062.
- [13] B. Dhinesh, R. Niruban Bharathi, J. Isaac Joshua Ramesh Lalvani, M. Parthasarathy, and K. Annamalai, "An experimental analysis on the influence of fuel borne additives on the single cylinder diesel engine powered by *Cymbopogon flexuosus* biofuel," *Journal of the Energy Institute*, vol. 90, no. 4, pp. 634–645, 2017, doi: 10.1016/j.joei.2016.04.010.
- [14] S. Karthikeyan and A. Prathima, "Environmental effect of CI engine using microalgae methyl ester with doped nano additives," *Transportation Research Part D*, vol. 50, pp. 385–396, 2017, doi: 10.1016/j.trd.2016.11.028.
- [15] M. S. Gad and S. Jayaraj, "A comparative study on the effect of nano-additives on the performance and emissions of a diesel engine run on Jatropha biodiesel," *Fuel*, vol. 267, no. October 2019, p. 117168, 2020, doi: 10.1016/j.fuel.2020.117168.

- [16] A. Prabu, "Nanoparticles as additive in biodiesel on the working characteristics of a DI diesel engine," *Ain Shams Engineering Journal*, vol. 9, no. 4, pp. 2343–2349, 2018, doi: 10.1016/j.asej.2017.04.004.
- [17] A. K. Pandian, R. B. B. Ramakrishnan, and Y. Devarajan, "Emission analysis on the effect of nanoparticles on neat biodiesel in unmodified diesel engine," *Environmental Science and Pollution Research*, vol. 24, no. 29, pp. 23273–23278, 2017, doi: 10.1007/s11356-017-9973-6.
- [18] P. C. Srinidhi, A. Madhusudhan, and S. V. Channappattana, "Effect of NiO nanoparticles on performance and emission characteristics at various injection timings using biodiesel-diesel blends," *Fuel*, vol. 235, no. March 2018, pp. 185–193, 2019, doi: 10.1016/j.fuel.2018.07.067.
- [19] H. Y. Nanlohy, H. Riupassa, I. M. Rasta, and M. Yamaguchi, "An Experimental Study on the Ignition Behavior of Blended Fuels Droplets with Crude Coconut Oil and Liquid Metal Catalyst," *Automotive Experiences*, vol. 3, no. 2, 2020.
- [20] T. Özgür, M. Özcanli, and K. Aydin, "Investigation of nanoparticle additives to biodiesel for improvement of the performance and exhaust emissions in a compression ignition engine," *International Journal of Green Energy*, vol. 12, no. 1, pp. 51–56, 2015, doi: 10.1080/15435075.2014.889011.
- [21] G. Sattonnay *et al.*, "Transition alumina phases induced by heat treatment of boehmite: An X-ray diffraction and infrared spectroscopy study," *Journal of Solid State Chemistry*, vol. 182, no. 5, pp. 1171–1176, 2009, doi: 10.1016/j.jssc.2009.02.006.
- [22] J. S. Basha, R. B. Anand, "The influence of nano additive blended biodiesel fuels on the working characteristics of a diesel engine," *Journal of the Brazilian Society of Mechanical Sciences and Engineering*, Vol 35, pp. 257–264, 2013, doi: 10.1007/s40430-013-0023-0.
- [23] R. L. Krupakaran, T. Hariprasad, A. Gopalakrishna, and P. Babu, "The performance and exhaust emissions investigation of a diesel engine using  $\gamma$ -Al<sub>2</sub>O<sub>3</sub> nanoparticle additives to biodiesel," *Carbon Management*, vol. 7, no. 3–4, pp. 233–241, 2016, doi: 10.1080/17583004.2016.1218713.
- [24] W. Xu and Y. Jiang, "Combustion Inhibition of Aluminum–Methane–Air Flames by Fine NaCl Particles," *Energies*, vol. 11, no. 11, 2018, doi: 10.3390/en11113147.
- [25] S. Masoumi, E. Houshfar, and M. Ashjaee, "Experimental investigation of the effects of passivated aluminum nanoparticles on butane flame structure," *Experimental Thermal and Fluid Science*, vol. 100, pp. 33–48, 2019, doi: 10.1016/j.expthermflusci.2018.08.025.
- [26] H. Venu and P. Appavu, "Al<sub>2</sub>O<sub>3</sub> nano additives blended Polanga biodiesel as a potential alternative fuel for existing unmodified DI diesel engine," *Fuel*, vol. 279, no. June, p. 118518, 2020, doi: 10.1016/j.fuel.2020.118518.
- [27] Y. Gan and L. Qiao, "Burning Characteristics of Fuel Droplets with Addition of Nanoparticles at Dilute and Dense Particle Loading," in *49th AIAA Aerospace Sciences Meeting including the New Horizons Forum and Aerospace Exposition*, 2011, no. January, pp. 1–10, doi: 10.2514/6.2011-795.
- [28] S. Hu *et al.*, "Assessment of uncertainties of laminar flame speed of premixed flames as determined using a Bunsen burner at varying pressures," *Applied Energy*, vol. 227, no. October 2017, pp. 149–158, 2018, doi: 10.1016/j.apenergy.2017.09.083.
- [29] I. K. G. Wirawan, I. N. G. Wardana, R. Soenoko, and S. Wahyudi, "Premixed combustion of kapok (Ceiba pentandra) seed oil on perforated burner," *International Journal of Renewable Energy Development*, vol. 3, no. 2, pp. 91–97, 2014, doi: 10.14710/ijred.3.2.91-97.
- [30] C. Tung and S. Hochgreb, "Measurements of laminar flame speeds of liquid fuels: Jet-A1, diesel, palm methyl esters and blends using particle imaging velocimetry (PIV)," *Proceedings of the Combustion Institute*, vol. 33, no. 1, pp. 979–986, 2011, doi: 10.1016/j.proci.2010.05.106.
- [31] X. Hu and H. Wei, "Experimental investigation of laminar flame speeds of propane in O<sub>2</sub>/CO<sub>2</sub> atmosphere and kinetic simulation," *Fuel*, vol. 268, no. February, p. 117347, 2020, doi: 10.1016/j.fuel.2020.117347.
- [32] H. S. Zhen, J. Miao, C. W. Leung, C. S.



- Cheung, and Z. H. Huang, "A study on the effects of air preheat on the combustion and heat transfer characteristics of Bunsen flames," *Fuel*, vol. 184, no. x, pp. 50–58, 2016, doi: 10.1016/j.fuel.2016.07.007.
- [33] H. Venu and V. Madhavan, "Effect of nano additives (titanium and zirconium oxides) and diethyl ether on biodiesel-ethanol fuelled CI engine," *Journal of Mechanical Science and Technology*, vol. 30, pp. 2361–2368, 2016, doi: 10.1007/s12206-016-0446-5.
- [34] B. Prabakaran and A. Udhoji, "Experimental investigation into effects of addition of zinc oxide on performance, combustion and emission characteristics of diesel-biodiesel-ethanol blends in CI engine," *Alexandria Engineering Journal*, 2016, doi: 10.1016/j.aej.2016.08.022.
- [35] K. Nanthagopal, B. Ashok, A. Tamilarasu, A. Johny, and A. Mohan, "Influence on the effect of zinc oxide and titanium dioxide nanoparticles as an additive with Calophyllum inophyllum methyl ester in a CI engine," *Energy Conversion and Management*, vol. 146, pp. 8–19, 2017, doi: 10.1016/j.enconman.2017.05.021.
- [36] S. Lee and R. J. Santoro, "Characterization of syngas laminar flames using the Bunsen burner configuration," *International Journal of Hydrogen Energy*, vol. 36, no. 1, pp. 992–1005, 2011, doi: 10.1016/j.ijhydene.2010.08.147.
- [37] A. F. Hery Soegiharto, I. N. G. Wardana, L. Yuliati, and M. Nursasongko, "The Role of Liquid Fuels Channel Configuration on the Combustion inside Cylindrical Mesoscale Combustor," *Journal of Combustion*, vol. 2017, 2017, doi: 10.1155/2017/3679679.
- [38] Y. Wu, V. Modica, B. Rossow, and F. Grisch, "Effects of pressure and preheating temperature on the laminar flame speed of methane/air and acetone/air mixtures," *Fuel*, vol. 185, pp. 577–588, 2016, doi: 10.1016/j.fuel.2016.07.110.
- [39] M. Mehl et al., "Experimental and modeling study of burning velocities for alkyl aromatic components relevant to diesel fuels," *Proceedings of the Combustion Institute*, vol. 35, no. 1, pp. 341–348, 2015, doi: 10.1016/j.proci.2014.06.064.
- [40] M. A. Trunov, M. Schoenitz, X. Zhu, and E. L. Dreizin, "Effect of polymorphic phase transformations in Al<sub>2</sub>O<sub>3</sub> film on oxidation kinetics of aluminum powders," *Combustion and Flame*, vol. 140, no. 4, pp. 310–318, 2005, doi: 10.1016/j.combustflame.2004.10.010.
- [41] Y. Huang, G. A. Risha, V. Yang, and R. A. Yetter, "Combustion of bimodal nano / micron-sized aluminum particle dust in air," *Proceedings of the Combustion Institute*, vol. 31, no. 2, pp. 2001–2009, 2007, doi: 10.1016/j.proci.2006.08.103.
- [42] T. Sikes et al., "Laminar flame speeds of nano-aluminum/methane hybrid mixtures," *Combustion and Flame*, vol. 166, no. April, pp. 284–294, 2016, doi: 10.1016/j.combustflame.2016.01.028.