

MECHTA

INTERNATIONAL JOURNAL OF MECHANICAL ENGINEERING
TECHNOLOGIES AND APPLICATIONS

ISSN 2722 - 3213

JUNE 2021

VOL. 2 - NO. 2



MECHANICAL ENGINEERING DEPARTMENT
UNIVERSITAS BRAWIJAYA, MALANG - INDONESIA

[Home](#) / [Editorial Team](#)

Editorial Team

Editor in Chief

Prof. Ir. Djarot Bangun Darmadi, MT., Ph.D., (SCOPUS ID: 52263615400; h index: 6), Universitas Brawijaya, Indonesia

Editors

Dr. Femiana Gapsari, ST, MT., (SCOPUS ID: 56012252900; h index: 6), Universitas Brawijaya, Indonesia

Dr.Ing. Victor Yuardi Risonarta, ST., M.Sc., (SCOPUS ID: 20434533200; h index: 3), Brawijaya University, Indonesia

Dr. Techn. Khairul Anam, ST., M.Sc., (SCOPUS ID: 56416256700; h index: 3), Universitas Brawijaya, Indonesia

Teguh Dwi Widodo, ST., M.Eng., Ph.D, (SCOPUS ID: 56258446700; h index: 4), Universitas Brawijaya, Indonesia

Reviewers

Prof. Mochammad Noer Iman, (SCOPUS ID: 50661418100; h-index: 8), Universitas Gajah Mada, Indonesia

Prof. Sudjito Suparman, (SCOPUS ID: 56165898100; h-index: 2), Universitas Brawijaya, Indonesia

About MECHTA

[Focus and Scope](#)[Publication Ethics](#)[Editorial Team](#)[Reviewer Acknowledgement](#)

[Plagiarism](#)

[Visitor Statistic](#)

[Author Fees](#)

Information

[For Readers](#)

[For Authors](#)

[For Librarians](#)

[Open Journal Systems](#)

[Make a Submission](#)

Journal Index



GARUDA
GARBA RUJUKAN DIGITAL



sinta
Science and Technology Index

S4

Tools

[Mendeley User Guide](#)

[Insert Citation using Mendeley](#)

Information for Author

[Author Guidelines](#)

[Online Submissions](#)

[Download Template](#)



[Home](#) / [Archives](#) / Vol. 2 No. 2 (2021)

Vol. 2 No. 2 (2021)

DOI: <https://doi.org/10.21776/MECHTA.2021.002.02>

Published: 2021-06-15

Articles

The Calculation of Expense Reduction based on the Efficiency of Cyclone by Computational Fluid Dynamic

Dhany Eko Wahyudi, Syarifa Nurâ€™aini, Wulandari Kusuma Dewi, Retno Mardiyah Aisyah, Eka Lutfi Septiani

85 - 90

 PDF

The Effect of Solution Treatment on Mechanical Properties and Micro Structure of Zr-10Ti-Sn Alloy for Screw Dental Implant Application

Deva Ayu Utami, R. Henny Mulyani, Djoko Hadi Prajitno

91 - 99

 PDF

Effect of Biodiesel B100 and Ethanol Blends on the Performance of Small Diesel Engine

Alfian Firdiansyah, Nasrul Ilminnafik, Agus Triono, Muh Nurkoyim Kustanto

101 - 106



PDF

Experimental Study of Updraft Gasification of Rice Husk and Coal to Produce Syngas

Figrei Akbar Nugroho, Akhmad Syarief, Allexyus Mikhael, Geovani Glen Supit

107 - 114



PDF

Key Performance Indicators Analysis for Quay Container Crane Performance Assessment (Case Study at Jakarta International Container Terminal)

Mufti Imam Pekih, Adelina Sembiring, Sugeng Santoso

115 - 125



PDF

Influence of Mixture Composition and Compaction Pressure of Briquette Made from Ironwood (Eusideroxylon Zwageri) Charcoal and Gelam (Melaleuca Cajuputi) on Combustion Characteristic

Akhmad Syarief, Nuryasin Qadimil Awaly, Muhammad Yusuf, Jerry Iberahim

127 - 136



PDF

The Influence of Leachate Water on Corrosion Rate of Mild Steel Plate

Abdul Ghofur, Dhonie Adetya Rachman, Muhammad Mochtar Lutfi, Fathur Rahman

137 - 143



PDF

Design of Automatic Feeder for Shrimp Farming Based on Internet of Things Technology

Ilham Arditya, Tri Ari Setyastuti, Fikri Islamudin, Iskandar Dinata

145 - 151



PDF

Application of Fiber Made from Bark of Salak (Salacca Zalacca) Tree as Reinforcement in Polymer Matrix Composites

Andromeda Dwi Laksono, Gusti Umindya Tajalla, Oliever Andrea Parusha

153 - 159



PDF

Analysis on Nylon 6/6 Camshaft Gear Temperature Simulation In A 1.1 Kva Elepaq Generator Using Inventor and ANSYS

Olalekan Abdulrahim Sanni, Sunday Ayoola Oke

161 - 169



About MECHTA

[Focus and Scope](#)

[Publication Ethics](#)

[Editorial Team](#)

[Reviewer Acknowledgement](#)

[Plagiarism](#)

[Visitor Statistic](#)

[Author Fees](#)

Information

[For Readers](#)

[For Authors](#)

[For Librarians](#)

[Open Journal Systems](#)

[Make a Submission](#)

Journal Index



GARUDA
GARBA RUJUKAN DIGITAL



sinta
Science and Technology Index

S4

Tools

[Mendeley User Guide](#)

[Insert Citation using Mendeley](#)

Information for Author

[Author Guidelines](#)

[Online Submissions](#)

[Download Template](#)



Alfian Firdiansyah

Graduate student
Magister programme
Department of Mechanical engineering,
University of Jember, Jawa-Timur
68121, Indonesia
alfian.firdiansyah@japfa.com

Nasrul Ilminnafik

Lecturer
Department of Mechanical engineering,
University of Jember, Jawa-Timur
68121, Indonesia
nasrul.teknik@unej.ac.id

Agus Triono

Lecturer
Department of Mechanical engineering,
University of Jember, Jawa-Timur
68121, Indonesia
agus.triono@unej.ac.id

Muh Nurkoyim Kustanto

Lecturer
Department of Mechanical engineering,
University of Jember, Jawa-Timur
68121, Indonesia
kustanto1969@gmail.com

Effect of Biodiesel B100 and Ethanol Blends on the Performance of Small Diesel Engine

A small diesel engine is a machine that has high efficiency but causes a high level of pollution. The most widely used fuel so far is fossil energy which is unrennewable energy. The fruit of the Calophyllum inophyllum plant has great potential to be developed as alternative energy for small diesel engines. In this study, the test fuel used was D100, B100, E5, E10, and E15. The small engine diesel used TG-R180 Diesel with a compression ratio of 20:1 at engine turns 1500, 1800, 2100, and 2400 rpm, and the braking load at a constant prony disc brake is 1,5 kg/cm². The result of the study using E10 fuel can improve engine performance and can reduce the opacity of the exhaust gas. The highest power in the D100 fuel at 2100 rpm is 8,06 PS. The highest thermal efficiency of E10 fuel is 50,29%. The use of Calophyllum inophyllum biodiesel (B100) can reduce exhaust gas opacity in small diesel engines when compared to the use of D100. E10 fuel has the lowest exhaust gas opacity rate of 4,1%.

Keywords: *Calophyllum Inophyllum Biodiesel, Ethanol, Small Diesel Engine*

1. INTRODUCTION

Calophyllum inophyllum plants are widely grown throughout Indonesia from Sumatera to Papua with an area of 255,3 thousand ha [1]. The advantage of using calophyllum inophyllum as an alternative energy is that this plant can be productive for up to 50 years, the oil content in calophyllum inophyllum fruit is around 40-73%, does not compete with feed needs (non-edible), has a high calorific value [2], The oil yield of the calophyllum inophyllum plant is 4680 kg/ha [3]. Biodiesel calophyllum inophyllum has a much lower exhaust gas opacity than diesel fuel [4].

Calophyllum inophyllum biodiesel and ethanol are alternative energy that can be used to reduce the use of fossil energy as fuel. The raw materials for making bioethanol come from natural resources in the form of plants or biomass containing sugar, starch and cellulose [5]. Ethanol is an alternative fuel that has a number of advantages over fossil fuels [5]. Ethanol can be used as a mixture of diesel fuel which can reduce exhaust emissions [6]. The addition of 10% and 15% ethanol to diesel fuel can reduce the performance of diesel engines due to the low calorific value of ethanol, but can reduce CO exhaust emissions [7]. The addition of ethanol to diesel fuel and biodiesel can reduce exhaust gas opacity [8]. The addition of 40% ethanol has a higher thermal efficiency than diesel fuel due to the high cetane number and enthalpy of evaporation [9]. The addition of ethanol can effect the viscosity of the fuel. The increase in the fuel rate is offset by the supply of air for the oxidation process which can make the flame higher [10].

The research needs to be done to determine the optimum exhaust gas performance and opacity in a diesel engine using a blend of calophyllum inophyllum biodiesel and ethanol.

2. MATERIALS AND METHODS

2.1 Characteristics of Biodiesel Calophyllum Inophyllum and Ethanol blends fuels

The calophyllum inophyllum plants used are from the Semarang city, Jawa Tengah. The proses of making biodiesel used degumming, esterification and transesterification methods [2]. The test fuels in this study were D100 (100% diesel fuel), B100 (100% calophyllum inophyllum biodiesel), E5 (95% calophyllum inophyllum biodiesel + 5% ethanol), E10 (90% calophyllum inophyllum biodiesel + 10% biodiesel). ethanol)

and E15 (85% calophyllum inophyllum biodiesel + 15% ethanol). The ethanol used in this study uses 99.6% ethanol and diesel fuel using Pertamina Dex.

2.2 Machine Installation Preparation

The test was carried out with the TG-R180 small diesel engine with specifications as shown in Table 1. Single cylinder, 4 stroke small diesel engine. Use of prony disc brake to determine the torque in the engine. Smoke tester to determine exhaust gas opacity. Research machine installation in Figure 1.

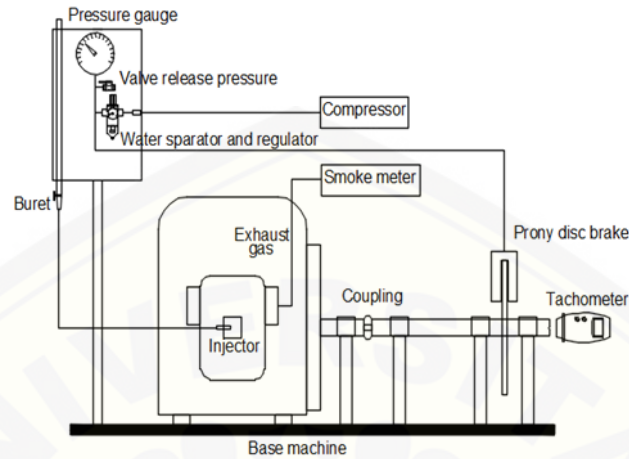

Figure 1: Research Installation

Tabel 1: Small diesel engine spesification

Specifications	Detail
Bore	80 mm
Stroke	80 mm
Cylinder volume	402 cc
Compression Ratio	20 : 1
Gasket Thickness	1,8 mm

Variations of fuel used D100, B100, E5, E10 and E15 at an engine compression ratio of 20:1. Engine speed variations 1500, 1800, 2100 and 2400 rpm. The prony disc brake is constant at 1,50 kg/cm². The parameters measured at the time of testing each fuel include the time of fuel consumption, the force generated on the prony disc brake scales and the exhaust gas opacity.

3. RESULTS AND DISCUSSIONS

The results of this study include the properties of calophyllum inophyllum biodiesel fuel, performance and exhaust gas opacity from a blend fuel of calophyllum inophyllum biodiesel and ethanol.

Properties biodiesel calophyllum inophyllum

The characteristics of calophyllum inophyllum biodiesel were tested and compared to biodiesel Bachtiar [10] and Atabani [11]. The difference in these characteristics can be seen in Table 2.

Table 2: Comparison of the characteristics of calophyllum inophyllum biodiesel

Properties	SNI 7182:2015[12]	Bachtiar[10] B100	Atabani[11] B100	Result Biodiesel			
				B100	E5	E10	E15
Densitas 40°C (kg/m ³)	850 - 890	843	866	887	880	877	869
Viskositas 40°C (cSt)	2,3 – 6,0	4,88	5,53	5,98	5,93	4,55	3,93
Nilai kalor (Cal/gr)	-	9448,9	-	5105,3	4792,18	4595,45	4693

Table 2 describes the characteristics of the fuel including its density at 40°C, viscosity at a temperature of 40°C and calorific value. The characteristics of calophyllum inophyllum biodiesel based on standard SNI 7182: 2015 biodiesel parameters can be used as an alternative fuel. The resulting calophyllum inophyllum biodiesel has a higher density and viscosity than Bachtiar [10] and Atabani [2]. The biodiesel produced in this study also has a lower heating value than Bachtiar [10]. Differences in fuel characteristics can be caused by differences in esterification and transesterification processes as well as differences in the use of catalysts. The factors that influence the transesterification process are the amount of alcohol and catalyst, reaction temperature, pressure and time [13]. Addition of ethanol to calophyllum inophyllum biodiesel can reduce viscosity, density and calorific value.

Performance and Emissions

Form the test results on a diesel engine fueled by a mixture of biodiesel and ethanol with variations in engine speed, the effective power, efficiency and opacity of the exhaust gas were obtained.

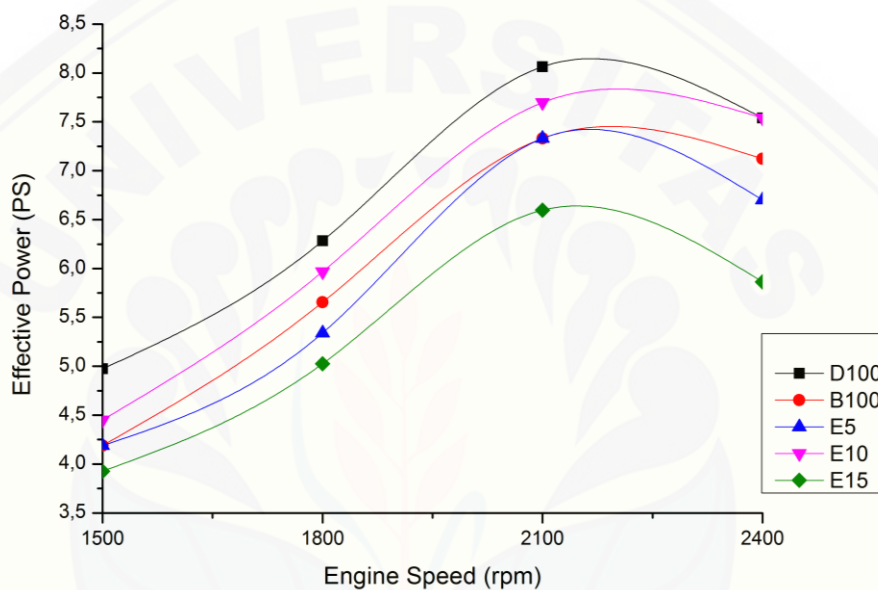

Figure 2. Graph of engine speed – effective power

Fig. 2 describes the relationship engine speed and effective power resulting in variations in fuel, indicating that the effective power of all types of fuel increases to a maximum point at 2100 rpm then decreases. These results are consistent with research conducted by Setyadji [14] and Robiul [15]. At 2400 rpm the effective power is getting smaller due to the weakened torque due to the moment of inertia on the engine [14]. Torque and effective power at high speed decreases due to greater mechanical losses and engine capacity [15].

D100 fuel has the greatest effective power compared to B100 and a blend of biodiesel calophyllum inophyllum and ethanol. The peak at 2100 rpm D100 produces an effective power of 8,06 PS . The lowest rated effective power is E15 fuel. This is because D100 fuel has the highest calorific value.

E10 fuel has a greater effective power than B100 fuel. In the results of this test there is a discrepancy with the research conducted by Can [7]. It is stated that the addition of ethanol can reduce the effective power generated due to reduce calorific value. However, this research correlates with the research conducted by Putrasari [16] and Gnanamoorthi [9]. It is stated that a suitable ethanol mixture in biodiesel can improve diesel engine performance due to higher fuel viscosity, lower cethane number and higher enthalpy of fuel evaporation [5], [9]. The viscosity of the fuel can affect the fluidity of the fuel [11]. An increase in the fuel rate offset by the supply of air for the oxidation process can cause a higher flame [10].

Fig. 3 is the resulting thermal efficiency generated for each test fuel at various engine speeds. Thermal efficiency has increased until 2100 rpm engine speed then decreased at 2400 rpm. Thermal efficiency at high rotation decreases because the machine experiences a lot of mechanical losses and the effective power

generated at high rotation is getting smaller due to the moment of inertia.

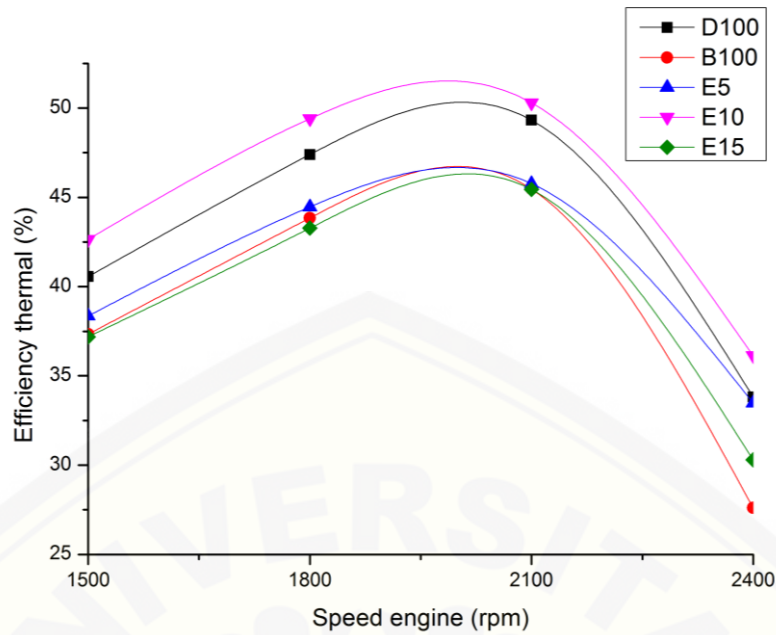

Figure 3. Graph of engine speed – efficiency thermal

E15 fuels have the lowest thermal efficiency trend. The effective power generated at low E15 combustion is due to the low calorific value of the fuel. E10 fuel has an efficiency rate of 50.29%. This thermal efficiency is the highest compared to other fuels. The results of this test are in accordance with previous research conducted by Gnanamoorthi [9]. The addition of ethanol to biodiesel can increase thermal efficiency in diesel engines. The addition of ethanol can also reduce fuel use or be more economical [5]. Apart from the high viscosity of the fuel, the cetane number, and the enthalpy of evaporation are also high because the blend of ethanol and fuel can cause micro-explosions [17], [18]. The micro explosion in combustion causes the secondary atomization of a fuel and causes combustion to accelerate and combustion is more complete, this is because the breakdown of fuel when combustion occurs into small particles that makes evaporation faster, so that the mixing of fuel and air is faster and combustion to be faster [17].

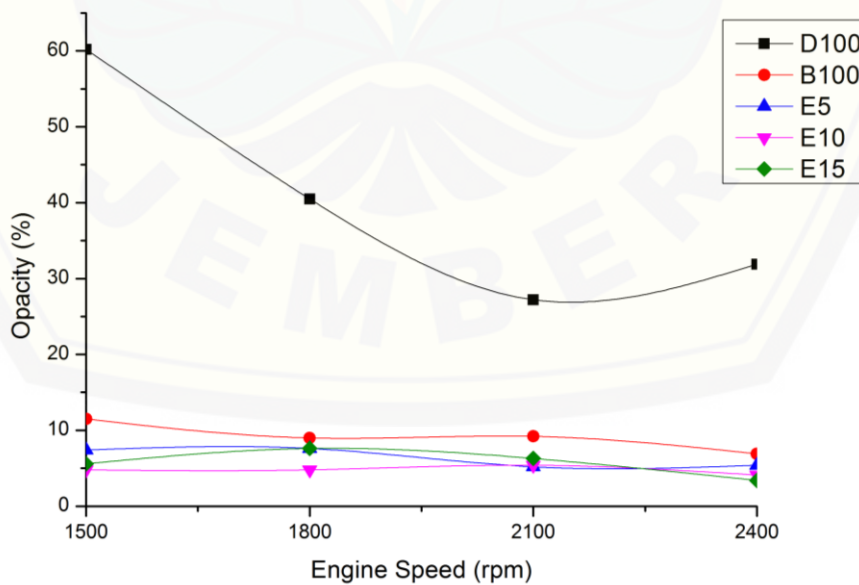

Figure 4. Graph of engine speed - opacity

Fig. 4 describes the relationship of engine speed to the opacity of the exhaust gas produced. Opacity of

calophyllum inophyllum biodiesel is lower than diesel fuel at engine speed. The highest opacity on the D100 fuel at 1500 rpm is 60.2%. Biodiesel calophyllum inophyllum forms less soot, lower residual content and fatty acids contained in biodiesel are easier to be completely oxidized [14]. This research is in accordance with previous research conducted by Nayak [4] and Fanani [19]. While the lowest opacity is on E10 fuel at 2400 rpm, which is 4.1%. In this fuel the exhaust gas opacity drops dramatically compared to D100 fuel, this is because the oxygen content in ethanol fuel and the micro-explosion in ethanol fuel also makes combustion more perfect [17], [18].

4. CONCLUSIONS

Calophyllum inophyllum Biodiesel fuel can be used as an alternative fuel as a substitute for fossil fuels. The use of a 10% ethanol blend percentage in calophyllum inophyllum biodiesel can improve engine performance and can reduce the opacity of the exhaust gas. The highest power on the D100 fuel at 2100 rpm engine speed is 8.06 PS. The highest thermal efficiency of E10 fuel is 50.29%. The use of biodiesel calophyllum inophyllum (B100) can reduce exhaust gas opacity in diesel engines when compared to the use of D100 and E10 fuel has the lowest exhaust gas opacity rate, which is 4.1%.

5. ACKNOWLEDGMENTS

Thanks to the agencies that have helped the completion of this research. Combustion engine laboratory Brawijaya University and SMKN 1 Wongsorejo Banyuwangi.

6. REFERENCES

- [1] S. BUSTOMI *et al.*, "Nyamplung (*Calophyllum inophyllum* L.) Sumber Energi Biofuel yang Potensial," *Badan Penelit. dan Pengemb. Kehutan.*, no. 0251, pp. 1–17, 2008.
- [2] A. E. ATABANI and A. D. S. CÉSAR, "Calophyllum inophyllum L. - A prospective non-edible biodiesel feedstock. Study of biodiesel production, properties, fatty acid composition, blending and engine performance," *Renew. Sustain. Energy Rev.*, vol. 37, pp. 644–655, 2014, doi: 10.1016/j.rser.2014.05.037.
- [3] A. KUMAR and S. SHARMA, "Potential non-edible oil resources as biodiesel feedstock: An Indian perspective," *Renew. Sustain. Energy Rev.*, vol. 15, no. 4, pp. 1791–1800, 2011, doi: 10.1016/j.rser.2010.11.020.
- [4] S. K. NAYAK, P. C. MISHRA, and M. M. NOOR, "Simultaneous reduction of nitric oxide and smoke opacity in TDI dual fuel engine fuelled with calophyllum-diesel blends and waste wood chip gas for modified inlet valve and injector nozzle geometry," *Energy*, vol. 189, no. x, p. 116238, 2019, doi: 10.1016/j.energy.2019.116238.
- [5] Y. PUTRASARIA, A. NURA, and A. MUHARAMA, "Performance and emission characteristic on a two cylinder di diesel engine fuelled with ethanol-diesel blends," in *Energy Procedia*, 2013, vol. 32, pp. 21–30, doi: 10.1016/j.egypro.2013.05.004.
- [6] J. LEI, L. SHEN, Y. BI, and H. CHEN, "A novel emulsifier for ethanol-diesel blends and its effect on performance and emissions of diesel engine," *Fuel*, vol. 93, pp. 305–311, 2012, doi: 10.1016/j.fuel.2011.06.013.
- [7] Ö. CAN, I. ÇELIKTEN, and N. USTA, "Effects of ethanol addition on performance and emissions of a turbocharged indirect injection Diesel engine running at different injection pressures," *Energy Convers. Manag.*, vol. 45, no. 15–16, pp. 2429–2440, 2004, doi: 10.1016/j.enconman.2003.11.024.
- [8] D. B. HULWAN and S. V. JOSHI, "Performance, emission and combustion characteristic of a multicylinder DI diesel engine running on diesel-ethanol-biodiesel blends of high ethanol content," *Appl. Energy*, vol. 88, no. 12, pp. 5042–5055, 2011, doi: 10.1016/j.apenergy.2011.07.008.
- [9] V. GNANAMOORTHY and G. DEVARADJANE, "Effect of compression ratio on the performance, combustion and emission of di diesel engine fueled with ethanol e Diesel blend," *J. Energy Inst.*, vol. 88, no. 1, pp. 19–26, 2015, doi: 10.1016/j.joei.2014.06.001.
- [10] H. H. BACHTIAR, B. A. FACHRI, and N. ILMINNAFIK, "Flame characteristics of diffusion of calophyllum inophyllum methyl ester on mini glass tube," *J. Adv. Res. Fluid Mech. Therm. Sci.*, vol. 57, no. 1, pp. 40–47, 2019.
- [11] A. E. ATABANI *et al.*, "A comparative evaluation of physical and chemical properties of biodiesel

- synthesized from edible and non-edible oils and study on the effect of biodiesel blending,” *Energy*, vol. 58, pp. 296–304, 2013, doi: 10.1016/j.energy.2013.05.040.
- [12] SNI, “Sni Biodiesel 2015,” 2015.
- [13] A. DEMIRBAŞ, “Biodiesel fuels from vegetable oils via catalytic and non-catalytic supercritical alcohol transesterifications and other methods: A survey,” *Energy Convers. Manag.*, vol. 44, no. 13, pp. 2093–2109, 2003, doi: 10.1016/S0196-8904(02)00234-0.
- [14] M. SETYADJI and E. SUSIANTINI, “Pengaruh Penambahan Biodiesel dari Minyak Jelantah pada Solar Terhadap Opasitas dan Emisi Gas Buang CO, CO₂ dan HC,” 2007, pp. 190–200.
- [15] A. R. A. UDIN and ADITYO, “PRESTASI MOTOR DIESEL DENGAN OPTIMALISASI SISTEM INTAKE MANIFOLD PAK SYS (PERFORMANCE AIR INTAKE SYSTEM) TURBO FAN AXIAL,” *J. Kotor*, vol. 10, no. 2 November, pp. 32–35, 2017.
- [16] Y. PUTRASARI, A. NUR, and A. MUHARAM, “Uji Prestasi Mesin Dual Fuel Menggunakan Diesel Etanol,” *Widyariset*, vol. 16 no 2, pp. 259–268, 2013.
- [17] ARWIN, L. YULIATI, and A. S. WIDODO, “Karakteristik Pembakaran Droplet Campuran Bahan Bakar Bensin-Etanol,” 2019, pp. 291–296.
- [18] X. ZHANG, T. LI, B. WANG, and Y. WEI, “Superheat limit and micro-explosion in droplets of hydrous ethanol-diesel emulsions at atmospheric pressure and diesel-like conditions,” *Energy*, vol. 154, pp. 535–543, 2018, doi: 10.1016/j.energy.2018.04.176.
- [19] G. FANANI, “Uji Prestasi dan Emisi Gas Buang Kendaraan dengan Bahan Bakar Biodiesel Nyamplung (*Calophyllum Inophyllum*),” Universitas Negeri Semarang, 2016.