

ISSN: 2186-2982 (Print) 2186-2990 (Online)

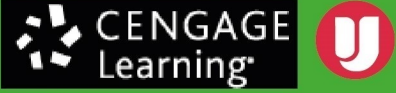

Scopus
EBSCO



International Journal of GEOMATE

(Geotechnique, Construction Materials and Environment)



Tsu, Japan

THE GEOMATE INTERNATIONAL SOCIETY

<https://www.geomatejournal.com>



Source details

Feedback > Compare sources >

International Journal of GEOMATE

Scopus coverage years: from 2011 to Present
Publisher: GEOMATE International Society
ISSN: 2186-2982 E-ISSN: 2186-2990

Subject area: Environmental Science: Environmental Engineering Agricultural and Biological Sciences: Soil Science
Earth and Planetary Sciences: Geotechnical Engineering and Engineering Geology Engineering: Building and Construction

Source type: Journal

[View all documents >](#) [Set document alert](#) [Save to source list](#) [Source Homepage](#)

CiteScore 2021 i
1.7

SJR 2021 i
0.360

SNIP 2021 i
0.721

CiteScore CiteScore rank & trend Scopus content coverage

i Improved CiteScore methodology x

CiteScore 2021 counts the citations received in 2018-2021 to articles, reviews, conference papers, book chapters and data papers published in 2018-2021, and divides this by the number of publications published in 2018-2021. [Learn more >](#)

Check out our new metric to help you evaluate journals! Dismiss Learn More

- General Information
- Web of Science Coverage
- Journal Citation Report

Return to Search Results

INTERNATIONAL JOURNAL OF GEOMATE [Share This Journal](#)

ISSN / eISSN **2186-2982 / 2186-2990**
 Publisher **GEOMATE INT SOC, MIE UNIV, GRAD SCH OF BIORESOURCES, TSU CITY, JAPAN, MIE 514-8507**

General Information

Journal Website	Visit Site	Publisher Website	Visit Site
1st Year Published	2011	Frequency	Quarterly
Issues Per Year	4	Country / Region	JAPAN
Primary Language	English		

Web of Science Coverage

Collection	Index	Category	Similar Journals ¹
Core Collection	Emerging Sources Citation Index (ESCI)	Engineering, Civil	Find Similar Journals

Search a topic within this journal

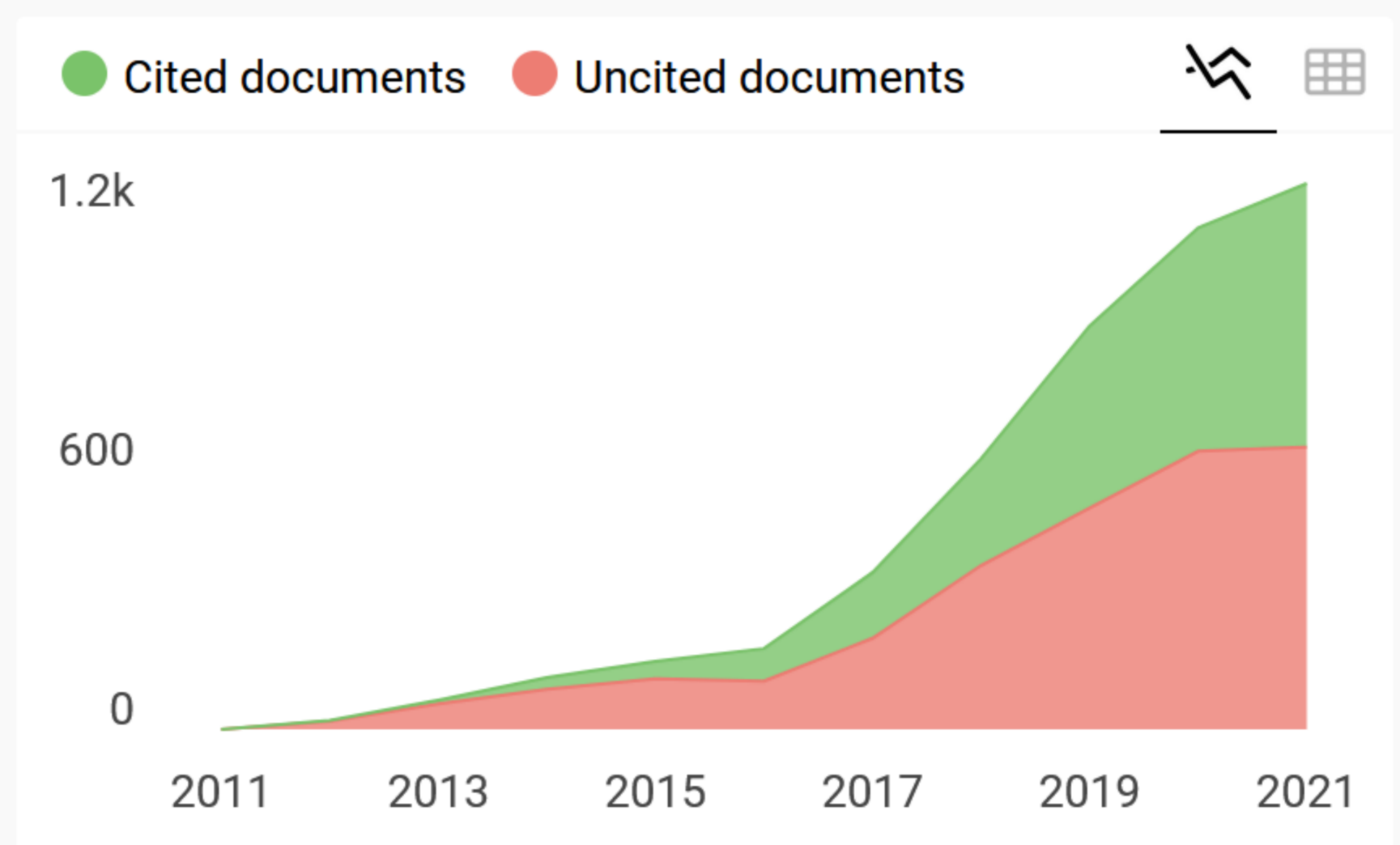
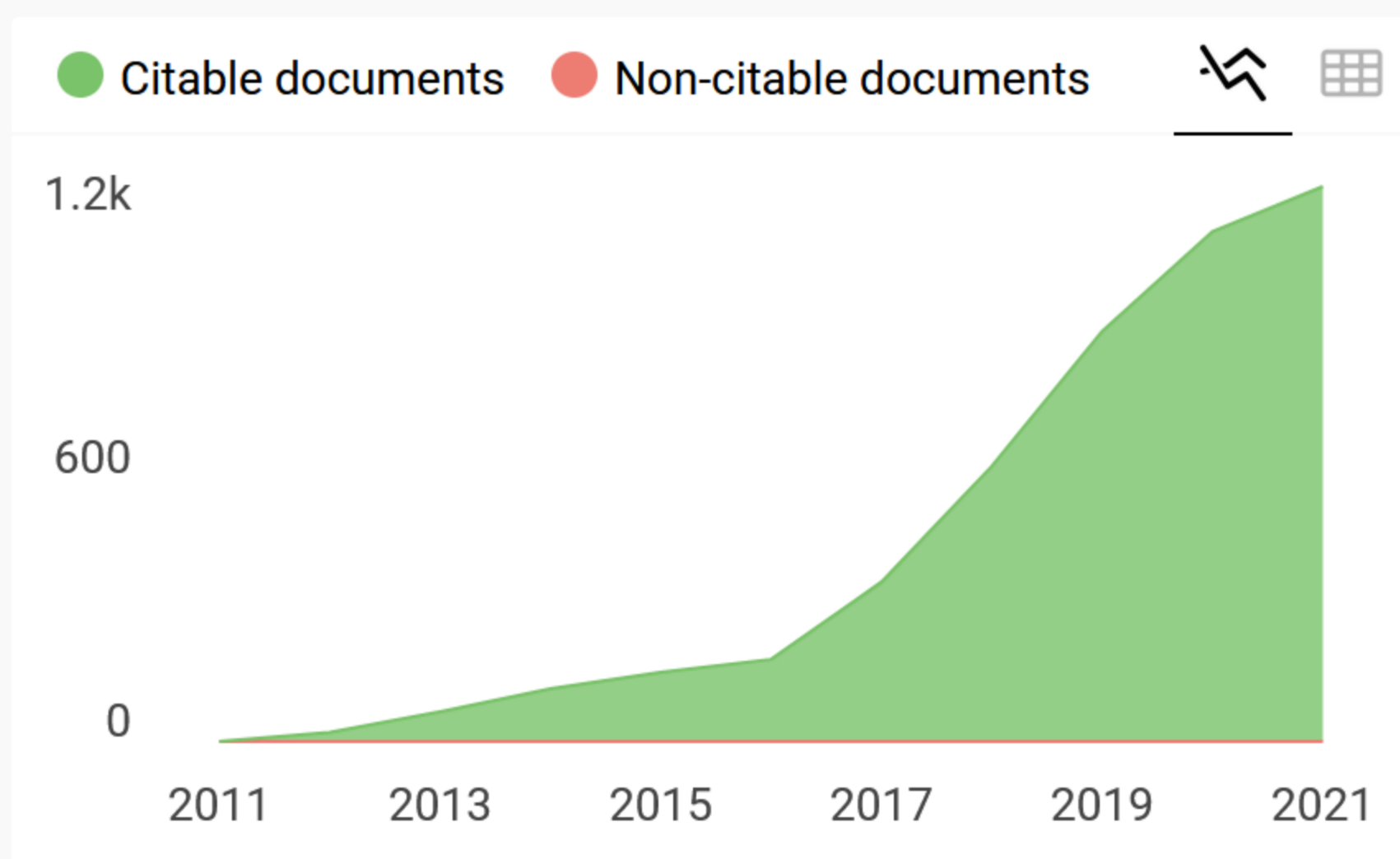
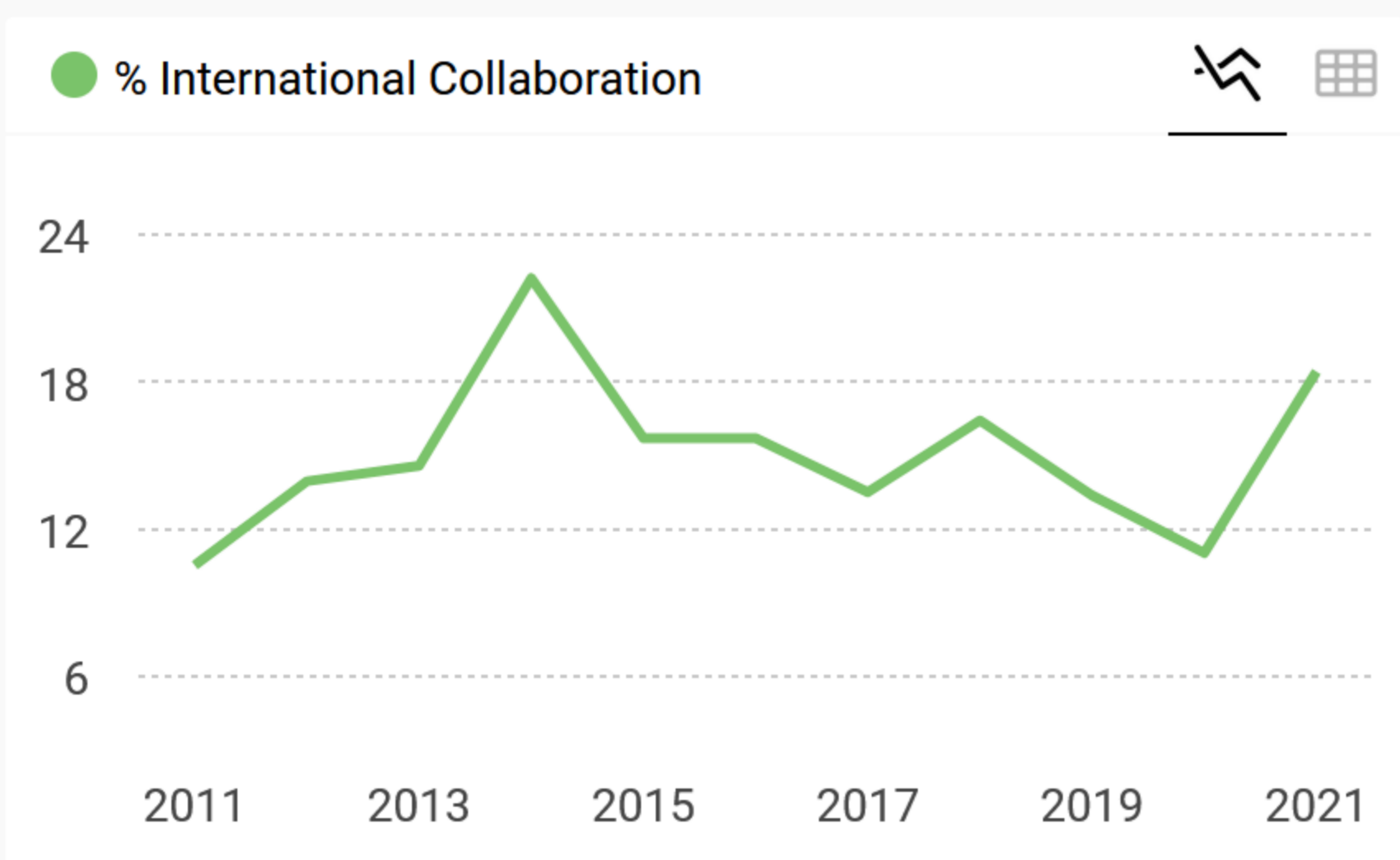
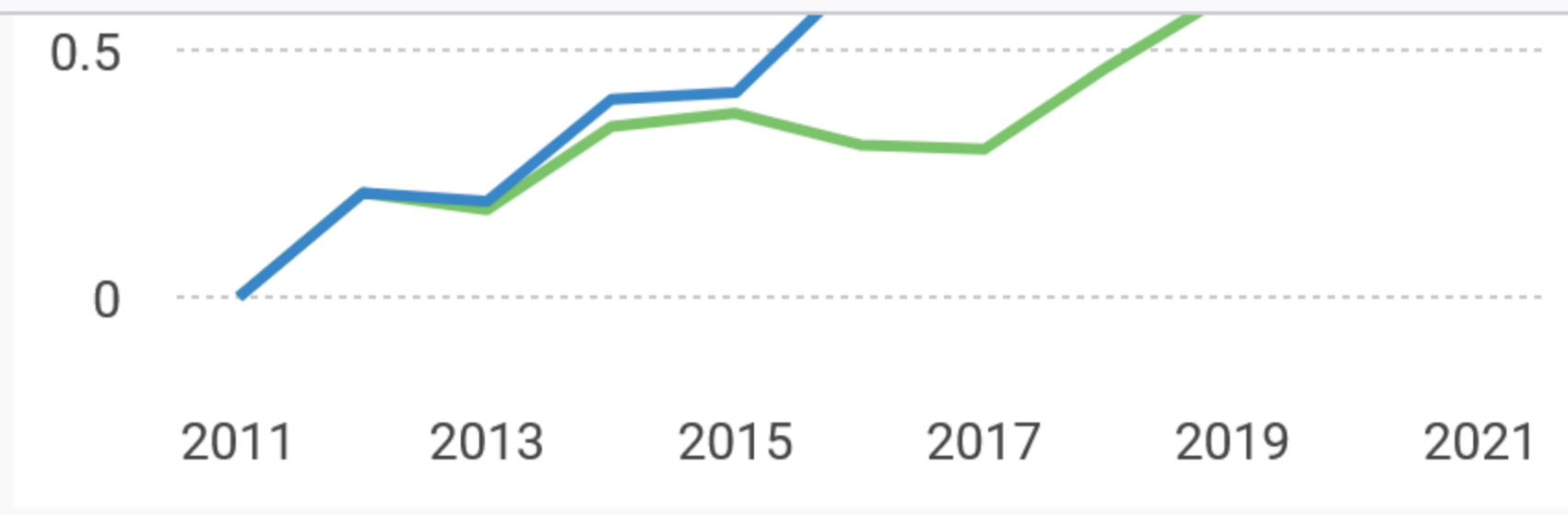
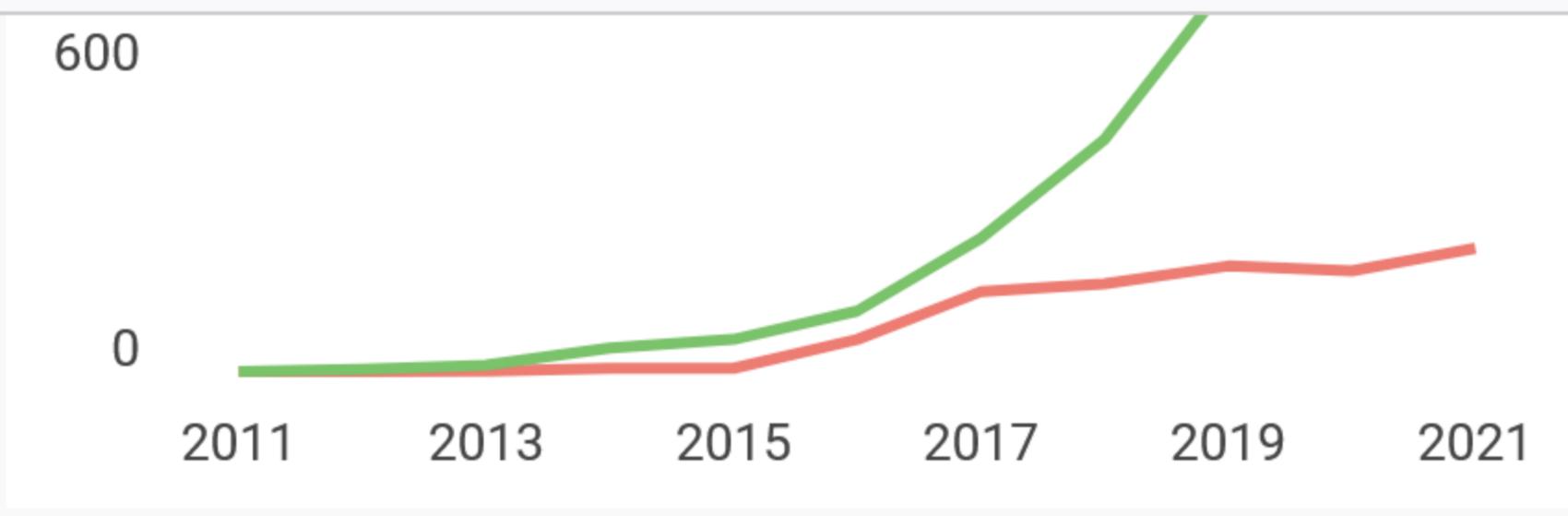

International Journal of GEOMATE

Q3 Building and Construction best quartile

SJR 2021 0.36

powered by scimagojr.com

Show this widget in your own website

Just copy the code below and paste within your html code:

```
<a href="https://www.scim
```

SCImago Graphica

Explore, visually communicate and make sense of data with our **new data visualization tool.**



[Home](#) / [Editorial Team](#)

Editorial Team

Editor-in-Chief

Prof. Dr. Zakaria Hossain, Mie University, Japan

Executive Editor-in-Chief

E/Prof. Dr. Takamitsu Kajisa, Mie University, Japan

Associate Editor-in-Chief

Associate Prof. Dr. John Victor Smith, RMIT University, Australia

Associate Editors:

Prof. Dr. Fumio Tatsuoka, Tokyo University of Science, Japan

Prof. Dr. Sai Vanapalli, University of Ottawa, Canada

Prof. Dr. Ian Jefferson, University of Birmingham, United Kingdom

Prof. Dr. Mounir Bouassida, National School of Engineering of Tunis

Prof. Dr. Bujang B.K. Huat, University Putra Malaysia, Malaysia

Prof. Dr. Nemy Banthia, University of British Columbia, Canada

Prof. Dr. Toshinori Sakai, Mie University, Japan

Prof. Dr. Valeriy Perminov, Tomsk Polytechnic University, Russia

Prof. Dr. Jing-Cai Jiang, University of Tokushima, Japan

Prof. Dr. Lilia Robles Austriaco, Angles University Foundation, Philippines

Prof. Dr. Muhammad Ibn Ibrahimy, International Islamic University, Malaysia

Prof. Dr. Shamsul I. Chowdhury, Roosevelt University, USA

Prof. Dr. Isabel Pinto, University of Coimbra, Portugal

Prof. Dr. Mark Jaksa, University of Adelaide, Australia

Prof. Dr. Kaneco Satoshi, Mie University, Japan

Prof. Dr. Junichiro Takeuchi, Kyoto University, Japan

Prof. Dr. Ranjith Pathegama Gamage, Monash University, Australia

Prof. Dr. Kingshuk Roy, Nihon University, Japan

Prof. Dr. Arif Ali Baig Moghal, NIT Warangal, India

Prof. Dr. Pedro Arrua, Universidad Tecnológica Nacional, Argentina

Prof. Dr. Miguel A. Pando, Drexel University, Philadelphia, USA

[Register](#)

[Login](#)



Tsu, Japan

International Journal of GEOMATE

(Geotechnique, Construction Materials and Environment)
ISSN: 2186 - 2982 (Print) 2186 - 2990 (Online)

[Home](#)

[About](#) ▾

[Editorial Board](#)

[Current](#)

[Archives](#)

[Membership](#) ▾

[Search](#)

[Content List](#)

[Home](#) / [Archives](#) / Vol. 25 No. 107 (2023): July 2023

[Submit your paper](#)

Vol. 25 No. 107 (2023): July 2023

Journal Menu

Published: 2023-05-02

[Guide for Authors](#)

[Paper Template, Copyright, etc.](#)

[Aims and Scope](#)

[Publication Ethics](#)

[Conferences](#)

Articles

EFFECT OF ROCK MASS DIAMETER ON RUNOUT DISTANCE AND VELOCITY ATTENUATION OF DRY GRANULAR AVALANCHE

Naoto Naito, Tatsuya Matsuda, Kinya Miura, Takumu Omura, Arif Daniel Bin

1-8

Azmi



PDF

Abstract View : 13

PDF downloads: 20

RESPONSE SURFACE MODELLING OF PERFORMANCE OF CONCRETE WITH BAUXITE LATERITE SOIL AND FLY ASH

Joemel Galupino, Mary Ann Adajar

9-16



PDF

Abstract View : 17

PDF downloads: 9

LONG-TERM DEFLECTION OF PRESTRESSED CONCRETE BOX GIRDER BRIDGES DUE TO CREEP AND SHRINKAGE

Luki Hariando Purba, Bambang Supriyadi, Bambang Suhendro

17-24



PDF

Abstract View : 10

PDF downloads: 10

UTILIZATION PATTERN AND POTENTIAL OF GELAM WOOD (MELALEUCA CAJUPUTI POWELL) AS A FOUNDATION STRUCTURE

[Reviewer Application and Policy](#)[Fee and Pay Link](#)

Scopus Indexed



Information

[For Readers](#)[For Authors](#)[For Librarians](#)

UNDERWORKING

Aigul Kozhas, Assel Mukhamejanova, Shamshygaiyn Toleubayeva, Gulshat Tleulenova, Akmaral Tleubayeva  95-106

 PDF

Abstract View : 13

PDF downloads: 9

STAKEHOLDERS' BARRIERS TO GREEN BUILDING PROJECT AT UNIVERSITAS GADJAH MADA INDONESIA

Rencya Pangarungan Rita, Ashar Saputra, Johan Syafri Mahathir Ahmad  107-114

 PDF

Abstract View : 11

PDF downloads: 5

EVALUATION OF SUSTAINABLE SEDIMENT MANAGEMENT IN SENGURUH RESERVOIR CONSIDERING AGE AND TRAPPING EFFICIENCY

Dian Sisinggih, Sri Wahyuni, Mokhammad Farid Maruf, Fahmi Hidayat  115-122

 PDF

Abstract View : 14

PDF downloads: 6

APPLICATION OF A FRACTIONAL STEP ALGORITHM FOR THE THREE-DIMENSIONAL SHALLOW WATER EQUATIONS IN A ROTATING SPHERICAL SURFACE

Medhat Helal

 123-132

 PDF

Abstract View : 10

PDF downloads: 13

LOAD SHARING MECHANISM OF BAMBOO PILE MATTRESS FOR REINFORCED EMBANKMENT

Mokhammad Farid Ma'ruf, Entin Hidayah, Sri Wahyuni, Dian Sisinggih, Paksitya Purnama Putra

 133-140

 PDF

Abstract View : 14

PDF downloads: 3

STUDY ON EFFECT OF PREVENTING EARLY AGE FROST DAMAGE USING ADDITIVE FOR SETTING TIME ADJUSTMENT

Jiahui Cui, Nguyen Duc Van, Yukio Hama

 141-148

 PDF

Abstract View : 6

PDF downloads: 2

LOAD SHARING MECHANISM OF BAMBOO PILE MATTRESS FOR REINFORCED EMBANKMENT

*Mokhammad Farid Maruf¹, Entin Hidayah¹, Sri Wahyuni², Dian Sisingih², and Paksitya Purnama Putra¹

¹Faculty of Engineering, Jember University, Indonesia; ²Faculty of Engineering, Brawijaya University, Indonesia

*Corresponding Author, Received: 10 Feb. 2023, Revised: 26 March 2023, Accepted: 02 April 2023

ABSTRACT: In Indonesia, bamboo pile mattress is commonly utilized for reinforced embankments over deep soft soil, especially for shallow ground water table or even over the ground surface as the water functions as timeless preservation for the bamboo. However hardly any articles have been published for design references. This work intends to evaluate bamboo pile mattress for embankment reinforcement numerically by means of Plaxis 2D. A parametric analysis was conducted to assess the effect of both piles spacing s and length L on embankment settlement, stability, and pile load ratio α_p . A ratio s/L is introduced to evaluate the combination of s and L effects. Furthermore, normalized settlement S/S_∞ and normalized factor of safety SF/SF_∞ are proposed to facilitate the assessment, in which S_∞ and SF_∞ are ones at $s/L = \infty$ (bamboo mattress with no pile condition). The results show that S/S_∞ increases with increasing s/L . Inversely, SF/SF_∞ and α_p decrease with decreasing s/L . When s and L are increased independently, S/S_∞ and SF/SF_∞ curves initially follow different paths. When $s/L > 0.1$ the curves merge into a line. Meanwhile, α_p curves blend into a line and separate with a different slope when $s/L > 0.1$. $s/L = 0.1$ becomes an onset point to show that L provides more significant effects than s for S/S_∞ and SF/SF_∞ at $s/L < 0.1$. However, L produces less influence on α_p than s at $s/L > 0.1$. Furthermore, the findings may provide insight and direction for reinforced embankment design using bamboo pile mattress.

Keywords: Bamboo pile mattress, Reinforced embankment, Settlement, Load transfer

1. INTRODUCTION

The demand for embankment construction on soft soil has risen over recent years. It becomes truly challenging for geotechnical engineers due to the probability of soil foundation failures and excessive settlements. The use of bamboo pile mattress is common practice in Indonesia to support embankments constructed over soft soil. Even though utilizing bamboo for construction is still in debate due to the short depletion time of bamboo compared with the construction lifetime. However, embankment reinforcement is critical during the construction stage or in the short term when soil strength has yet to be mobilized to gain strength improvement [1]. After the end of construction, gradually the soil strength increases due to the consolidation process, and the embankment's stability increases as well.

The application of bamboo for field soil reinforcement was highlighted in [2, 3]. Bamboo may be used for retaining walls, slope stabilization, soil stabilization, reinforced embankment support, and even for vertical drain [4].

For building a road in a muddy area, a bamboo net system was used to support geotextile [5]. The geotextile was put on top of the bamboo net to avoid stress concentration and also to make the road embankment more stable. The bamboo poles that

form the net system generate buoyant force to reduce the embankment settlement.

[6] also confirmed that the effect of bamboo net and geotextile composite on increasing bearing capacity. When bamboo net is used to support geotextile, the bearing capacity is significantly higher than when geotextile is used alone.

Prof. Masyhur Irsyam might have been the first person to use a bamboo pile mattress as a support embankment [7]. In the discharge canal embankment project, he changed the high-strength geotextile reinforcement into three layers of bamboo mattress and low-strength geotextile. The main reason for the alteration was simply to overcome construction difficulties and avoid a lack of high strength geotextile.

After the first bamboo mattress project went well, more clusters of bamboo poles were added to the mattress to make a bamboo pile mattress [8]. [1]. The full-scale test showed that the bamboo pile mattress system could keep highway embankments stable even on very soft soils. The bamboo pile mattress was also successfully applied for a double track railway project constructed over submerged soft soil [9, 10]. The reinforcement system provided better stability compared with limestone reinforcement for the embankment over the submerged soft soil layer.

Similar reinforcement was used for container

yard reclamation and railway embankments near shore areas [11], as well as the recent Semarang-Demak toll road built over coastal areas [12]. The toll road was also functioning as a sea embankment to prevent tidal flooding.

Bamboo pile mattress have been widely applied in a number of projects in Indonesia, including lifeline infrastructure projects. However, only a few articles are available for design references. This study intends to evaluate the behavior of bamboo pile mattress for embankment reinforcement with various pile spacings s and lengths L . The evaluation is conducted numerically by utilizing the commercial software Plaxis2D to simulate various scenarios. The study's findings should look into the effects of s and L on embankment settlement, stability, and load sharing of bamboo piles. Furthermore, the findings should enrich the knowledge of reinforced embankment technology and could help guide the design of embankment reinforcement on soft soil using bamboo pile mattress.

2. ON THE BAMBOO PILE MATTRESS

Bamboo pile mattresses are made by combining bamboo pole mattresses with pile-like bamboo pole clusters (Fig.1). The mattress is made of bamboo poles, which are arranged in a row and tied with palm fiber. It is composed of 3–7 mattress layers. The pile, on the other hand, is made up of 3–7 bamboo poles that are joined together.

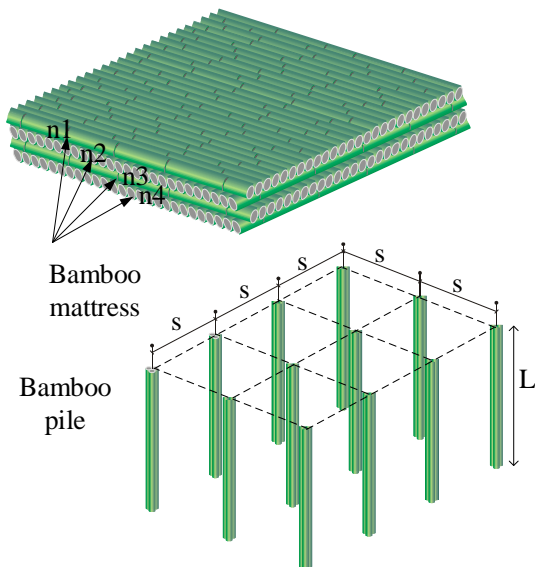

Fig.1 Bamboo pile mattress system (modified from [11])

According to [11], bamboo pile mattress is suitable for low-rise embankments and soft soil with a high ground water table, or when the water table is above the ground surface. The bamboo

mattress should be put on the ground surface. The mattress would be pushed down by subsoil settlement until it was submerged. The water table could act as timeless preservation for bamboo. However, the embankment is subjected to consolidation settlement but not differential settlement.

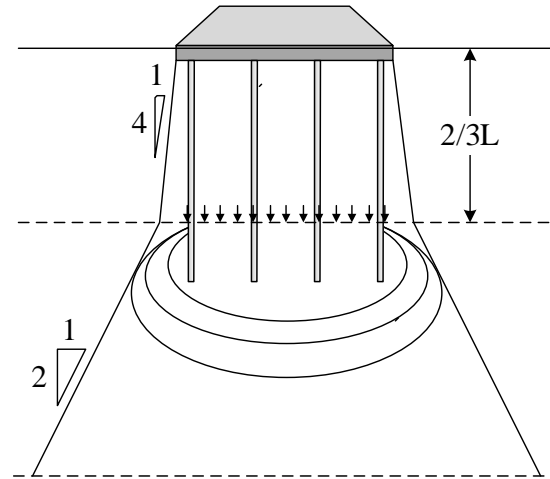

Fig.2 Load distribution of bamboo pile mattress system

The Terzaghi theory of 1D consolidation is applicable to bamboo pile mattress for settlement prediction. The load distribution moves downward about $2/3L$ to the base of an equivalent mattress (Fig.2). It changes the subsoil that is subjected to consolidation into a deeper layer and the stability of the embankment system as well.

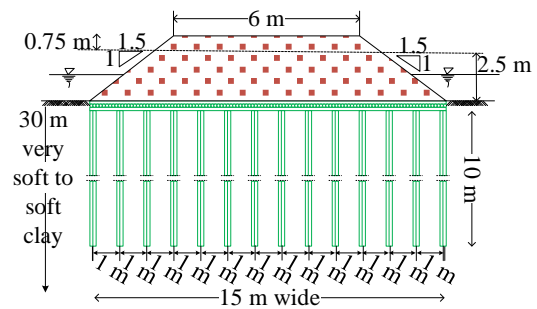

Fig.3 Embankment cross section [8]

3. 2D MODEL DEVELOPMENT

This study used the results of the full-scale instrumented reinforced trial embankment test, which was described in [8]. Figure 3 depicts the cross section of the embankment, and Table 1 describes the soil properties. The data required for numerical modeling but unavailable in [8] was determined with the assistance of the soil correlation table [13, pp. 127-132].

Table 1 Field soil properties [8]

Depth (m)	Soil type	c (kN/m ²)	γ (kN/m ³)	e_o
0 – 23	Very soft clay	6 – 15	14	2
23 – 25	Soft clay	15 – 35	15	1,8
25 – 30	Medium clay	35 – 55	16	1
> 30	Stiff to very stiff clay	55 – 150	16	

To create a bamboo piled mattress, four layers of bamboo mattress were joined together with bamboo cluster piles (Fig.1). Each pile contains three bamboo poles. The piles were arranged with distance s among others.

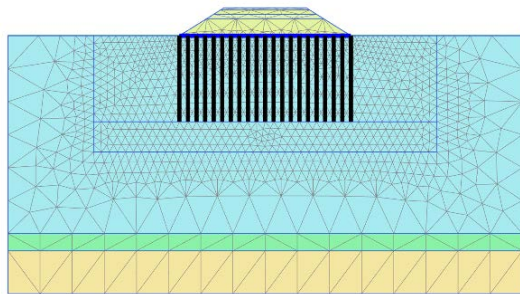

Fig.4 Generated mesh for Plaxis modeling

The reinforced embankment was numerically analyzed by means of Plaxis 2D. The generated mesh of the model is presented in Fig.4. The soil was simply modeled using the Mohr Coulomb model.

The mattress is represented as a beam structure, and the bamboo pile is a node to node anchor. Node to node anchor is preferred over beam because, as shown in Fig.5, beam is actually a representation of beam wall and requires beam parameter adjustment to represent piles [14]. Modeling bamboo piles as beam structures in 2D plane strain may overestimate pile strength support.

Cross section area and the length of bamboo pile are represented into spring constant k to determine pile's modulus of elasticity EA as follows:

$$F_{max} = \frac{P_{ult}}{SF} \quad (1)$$

Where F_{max} is maximum load capacity of pile; P_{ult} is ultimate pile bearing capacity; and SF is safety factor. It is assumed that F should be mobilized when the bamboo pile deforms about $0.1d$, where d is the bamboo pile diameter. Following Fig.6, EA can be determined as follows:

$$k = \frac{F_{max}}{d} \quad (2)$$

$$EA = kL \quad (3)$$

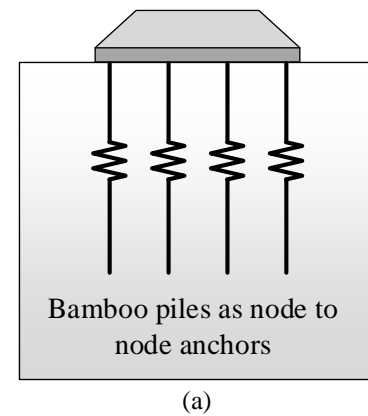
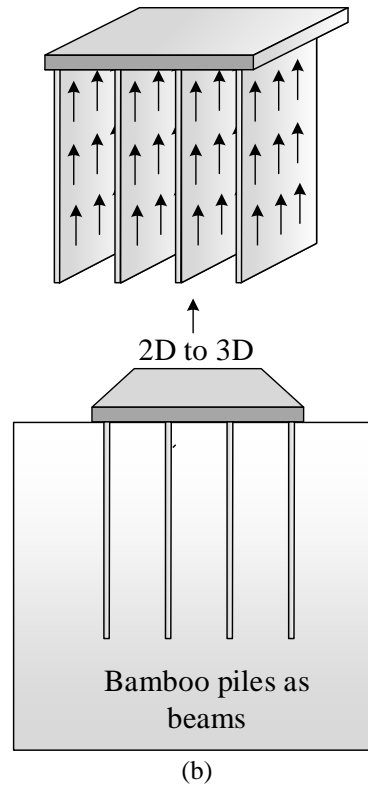

Fig.5 Bamboo pile model in 2D plane: (a) Node to node anchor, (b) Beam structure

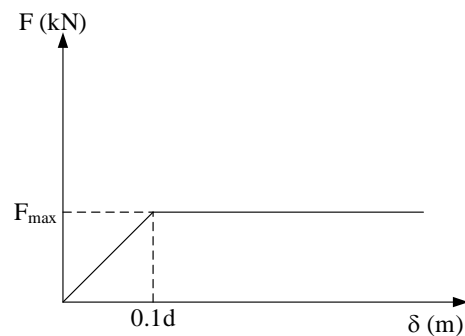

Fig.6 F_{max} mobilization

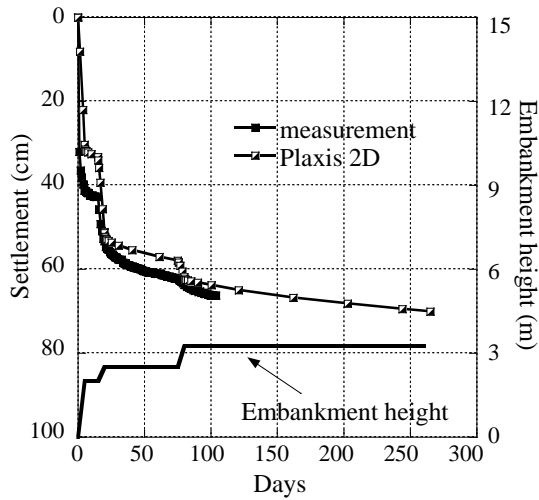

Fig.7 Calibration of simulation results with measurement settlement.

4. RESULT

4.1 Model Calibration with Embankment Settlement

Figure 7 presents how the settlement of the embankment was used to verify the simulation results. It shows that the trial embankment stage was initiated with 2 m of fill for 20 days and followed by additional fill consisting of 2.5 m for the first 20 days and additional fill up to 3.25 m at day 80. The consolidation process was applied once after the first stage for 55 days and again following the final backfill until day 260.

Figure 7 clearly shows that Plaxis 2D simulation result slightly underestimates the settlement but is acceptable. However, elastic settlement during the backfilling process on days 20 and 75 is higher than measured settlement. The simulation earns a safety factor of 1.81, which is clarified by [8], where the reinforced embankment system was stable and no failure was reported. Fig.7 verifies that the 2D model provides results that are in good agreement with the measured trial embankment settlement.

4.2 Parametric Analysis

Using a similar model, a parametric sensitivity analysis was done to look at the effects of bamboo pile distance s , length L , and number of mattress layers n . The load transferred from the mattress to the soil and bamboo piles beneath is evaluated to determine the portion of the load carried by the piles.

The setup for parametric analysis is as follows:

- $s = 1$ m; $n = 4$; $L = 3$ m, 4 m, 5 m, 6.5 m, 10 m, 15 m, 20 m.
- $L = 10$ m; $n = 4$; $s = 0.5$ m, 1.0 m, 1.5 m, 2.0 m, 2.5 m, 3.0 m.
- $L = 10$ m; $s = 1$ m; $n = 3, 4, 5, 6, 7$.

For the control condition ($s/L = \infty$), a reinforced embankment with four layers ($n = 4$) of bamboo mattress without bamboo pile was also simulated. Normalized settlement S/S_∞ and normalized factor of safety SF/SF_∞ are introduced to aid in the assessment. S_∞ and SF_∞ are associated parameters at $s/L = \infty$ (bamboo mattress with no pile condition).

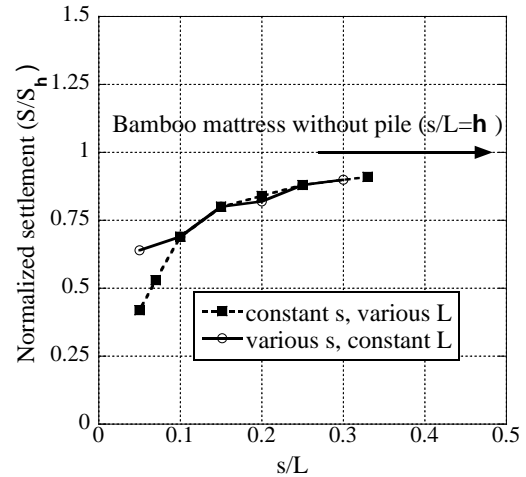

Fig.8 Settlement for various s/L

4.2.1 The effect of s/L on settlement

Figure 8 depicts S/S_∞ for various s/L . It clearly shows that the settlement increases proportionally with an increase in s/L . Bamboo piles added to bamboo mattress reduces embankment settlement. Closer rows of the piles reduce settlement by up to 0.7 times when $s/L = 0.1$. Further lowering of $s/L < 1$, increasing L causes less settlement than lowering s .

This result is in line with [15], the used of more piles decreased embankment settlement [16-18]. However, increasing pile spacing with the same number of piles and raft area should expand the pile coverage area [19]. The wider the pile coverage area, the smaller the settlement. The settlement began to increase when s surpassed 5 m.

4.2.2 The effect of s/L on safety factor

In contrast to settlement, SF/SF_∞ decreases proportionally with increasing s/L (Fig. 9). The larger the embankment settlement, the smaller the factor of safety. $s/L = 0.1$ becomes a threshold below which changes in s and L provide different safety factor behaviors. Changing L results in a larger SF than changing s . SF/SF_∞ at $s/L = 0.1$ is approximately 1.2 times SF/SF_∞ . The increasing stability of the embankment due to reinforcement has already been identified by [20-22]. Their results showed that the pile arrangement and the distance from the embankment's edge may affect the factor of safety, especially when the pile raft was constructed on sloping ground [15, 22].

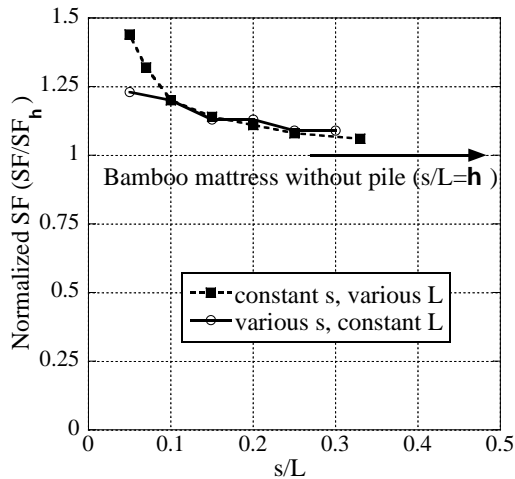

Fig.9 Safety factor for various s/L

4.2.3 The effect of s/L on load sharing ratio

The bamboo pile mattress reinforced embankment system is made up of the embankment, the mattress, the piles, and the subsoil. The total load due to the soil embankment Q_t is equal to the contact pressure between the bamboo mattress and the underneath soil Q_m and the load carried by piles Q_p . The pile load sharing ratio α_p can be represented as a ratio between Q_p and Q_t as follows:

$$\alpha_p = \frac{Q_p}{Q_t} \tag{4}$$

When $\alpha_p = 0$, it means only bamboo mattress without pile, which can be represented as $s/L = \infty$.

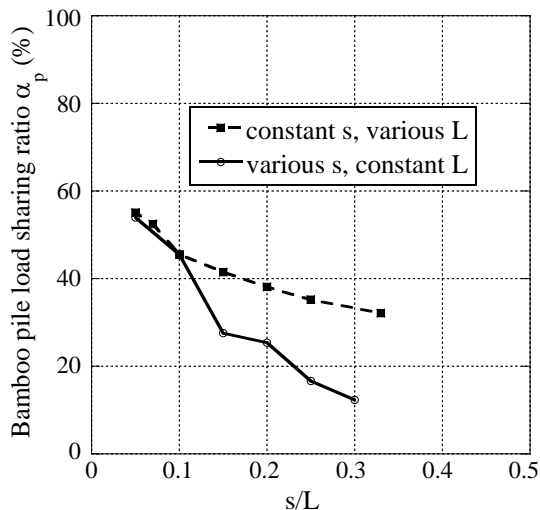

Fig.10 Portion of load carried by bamboo piles for various s/L

The influence of s/L on α_p be assessed in Fig.10 in which α_p decreases with increasing s/L . Unlike settlement and factor of safety, load sharing ratios that vary with s and L are merged in a single line when $s/L < 0.1$. The lines then separate for

additional s/L increments, demonstrating that increasing s has a greater influence than increasing L . Moreover, the number of piles is more significant than the length of piles.

The trend of load sharing shown in Fig.10 agrees with previous work reported by [16, 17, 23, 24]. In contrast, [25] reported that pile load sharing increased with increasing pile spacing. It was likely due to the increasing pile spacing without an increase in the number of piles. It increased the load transferred to bamboo piles by expanding the pile coverage area.

4.2.2 The effect of bamboo mattress layer number n

Variations of bamboo mattress layer n could be evaluated in Fig.11. In general, the number of mattress layers has less significant effects on settlement, factor of safety, and pile load sharing ratio.

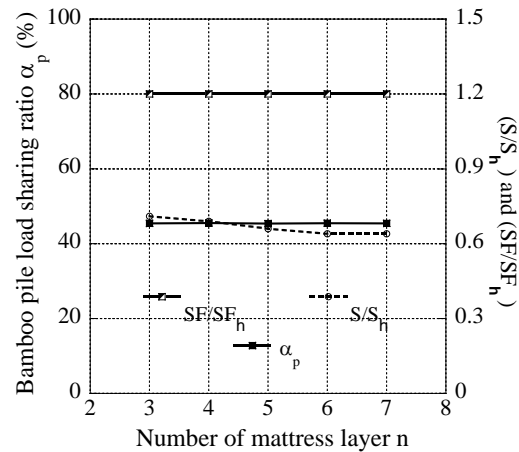

Fig.11 The effects of mattress layer number n

More mattress layers imply more bamboo mattress thickness. The less significant effects of thickness are supported by previous reports in [18, 26, 27]. They published both experimental and numerical results to show that raft thickness and rigidity had an insignificant influence on pile raft foundation systems. Instead, raft thickness and rigidity may reduce differential embankment settlement [28].

4.3 Discussion

The bamboo pile mattress embankment system functions more like a pile raft than an ordinary piled embankment. Based on raft and pile dimensions, the piled raft system can be categorized into two groups, namely, small and large pile raft [29]. Piled raft is classified as small if the ratio between raft width B and pile length L is less than unity ($B/L < 1$). Piles must be added to the raft to provide adequate bearing capacity and achieve a tolerable average

settlement. large piled raft requires pile to reduce settlement and raft bending moment. Whereas large piled raft requires piles to reduce settlement and the raft's bending moment. Large raft foundations on deep clay deposits are typically designed with adequate bearing capacity but still produce excessive settlement [30].

The parametric analysis results show that $s/L = 0.1$ is the onset point of the shifting of the curves for settlement, factor of safety, and pile load sharing ratio. For settlement and the factor of safety, at the beginning the curves show a different trend and become merged into a line when s/L is more than 0.1. The variation of s causes the curves to slope gradually for all s/L conditions. When L varies, however, the curves have a significant slope at first and then move gradually when $s/L > 0.1$.

This full-scale embankment test was conducted in deep, very soft soil layers. The bamboo piles can be classified as friction piles. Lengthening the bamboo piles will increase the pile surface area. The larger the surface area of the bamboo piles, the greater their friction bearing capacity, and consequently, the lower the settlement. It supports the study in [31] that addressed the reduction of the pile raft system due to pile length being more significant than that of pile addition and reducing pile spacing. For softer soil, the effects of pile addition and decreasing pile spacing became less significant. The effect of pile length was more significant for softer soil.

Terzaghi's consolidation theory, illustrated in Fig.1, could be used to examine the decrease in settlement caused by increasing L . The longer the pile length, the deeper the equivalence mattress moves downward. It thins the soil layer that is subjected to consolidation, resulting in less settlement. It is clarified by Fig.12 to show that the area affected by high excess pore pressure significantly decreases when the length of the pile increases. A smaller excess pore pressure area implies a smaller soil layer that was subjected to consolidation to prevent more settlement.

The factor of safety behaves in the opposite way as settlement. It is clearly clarified by Fig.13. in which the factor of safety is inversely proportional to settlement. Increasing s/L , which increases the settlement, implies a decrease in the factor of safety.

In a piled embankment system, load transfer from embankment loads to subsoil may be complicated. Without a load transfer platform, the embankment only puts a small amount of weight on the piles. When pre-tension geotextiles were installed, they caused arching effects, which transferred more weight to the piles [32]. If there were more geotextiles in place and the pre-tension was higher, they could work like a load transfer platform. Furthermore, higher geotextile tension reduced differential settlement. Similar findings

were reported by [33], demonstrating that the pile load ratio increased proportionally with increasing geotextile tension.

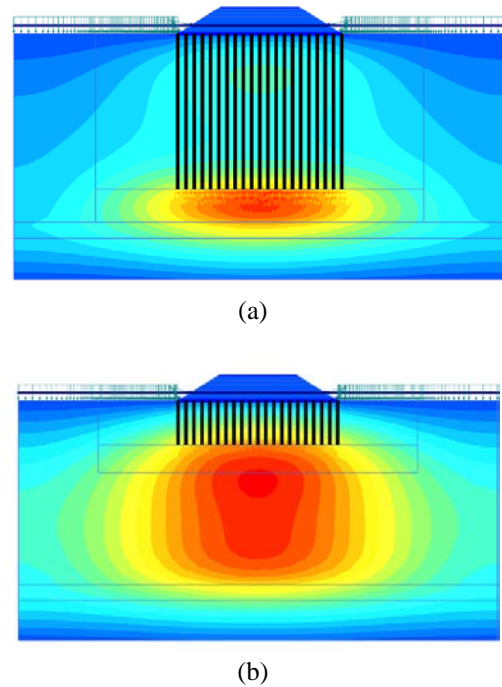

Fig.12 Excess pore pressure distribution: (a) Long piles, (b) Short piles

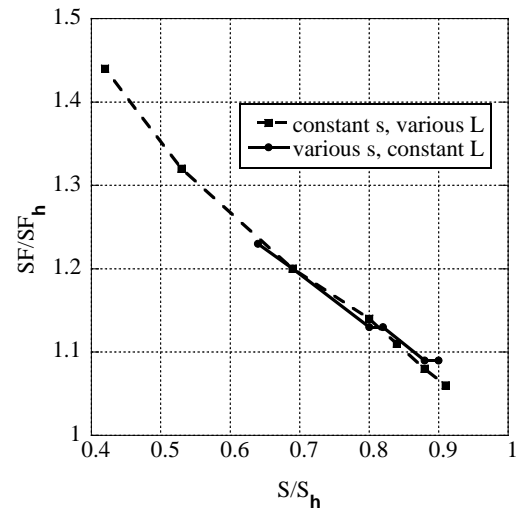

Fig.13 SF/SF_{∞} vs S/S_h relationships

Bamboo mattress might act as a load transfer platform to transmit embankment load to piles and subsoil. The addition of bamboo piles, combined with a reduction in pile spacing, should increase the amount of load carried by piles. In addition, bamboo mattress performs as a beam that works in synergy with bamboo piles to reduce lateral movement of the pile group and embankment system [34]. The bending moment applied to the

pile should be reduced and equalized, implying an increase in the vertical load distributed to piles. The greater the load carried by piles, the lower the contact stress between the mattress and subsoil, preventing further settlement.

5. CONCLUSIONS

A numerical simulation was conducted to assess the effects of bamboo pile spacing and length on reinforced embankments using bamboo pile mattress. A normalized settlement and a normalized factor of safety are introduced to evaluate the behavior of the embankment system. The results show that increasing s/L should increase the settlement and pile load sharing ratio but decrease the factor of safety. Comparing with bamboo mattress without piles, the settlement decreases by 0.7 times while the factor of safety increases by 1.2 times when $s/L = 0.1$. $s/L = 0.1$ becomes the onset point for settlement, factor of safety, and the load sharing ratio. Initially, S/S_∞ and SF/SF_∞ curves changed differently as s and L increased independently. The curves blended into a line when $s/L > 0.1$ and then blend into a line. α_p curves blended into a line and separate with a different slope when $s/L > 0.1$. At $s/L < 0.1$, L provides more significant effects than s for S/S_∞ and SF/SF_∞ . Meanwhile, L produces less influence on α_p than s at $s/L > 0.1$. Furthermore, the findings may provide insight and guidance for reinforced embankment design using bamboo pile mattress.

6. ACKNOWLEDGMENTS

The first author intends to deliver his thank to his teacher, Prof. Masyhur Irsyam, for his kind sharing of knowledge and experiences about bamboo mattress.

7. REFERENCES

- [1] Jewell R. A., The mechanics of reinforced embankments on soft soils. *Geotextiles and Geomembranes*, Vol. 7, No. 4, 1988, pp. 237–273.
- [2] Ma'ruf M. F., A Review on the Use of Bamboo for Earthwork Construction. *MATEC Web of Conferences*, Vol. 138, 2017, pp. 1-8.
- [3] Talib F. M., Mohamad H. M., and Mustafa M. N., Peat Soil Improvement with Bamboo Reinforcement Technology: A Review. *International Journal of GEOMATE*, Vol. 21, Issue 88, pp. 75–85.
- [4] Aziz M. A., A new method of stabilization of soft soils. *International Conference on Case Histories in Geotechnical Engineering*, 1984, pp. 6–11.
- [5] Toh C. T., Chee S. K., Lee C. H., and Wee S. H., Geotextile-bamboo fascine mattress for filling over very soft soils in Malaysia. *Geotextiles and Geomembranes*, Vol. 13, No. 6–7, 1994, pp. 357–369.
- [6] Khatib A., Zain M., Yusuf, and Marto A., Bearing Capacity of Soft Soil Using Bamboo-Geotextile Composite. *Jurnal Saintis*, Vol. 8, 2005, pp. 61–69.
- [7] Irsyam M., Stability Analysis for Coastal Embankment, A Case Study at the Discharge Canal Embankment of the Tambak Lorok Combine Cycle Power Plan. *International Symposium on Offshore Engineering*, Bandung., 1996, pp. 1–20.
- [8] Irsyam M., Krisnanto S., and Wardhani S. P. R., Instrumented full scale test and numerical analysis to investigate performance of bamboo pile-mattress system as soil reinforcement for coastal embankment on soft clay. *The 2nd International Conference GEDMAR08, Nanjing, China Geotechnical Engineering for Disaster Mitigation and Rehabilitation*, Vol. 501–504, 2008, pp. 165–170.
- [9] Darjanto H., and Ma'ruf M. F., Project Report of KJGJM-1 Package. *Soft Soil Reinforcement for Double Track Railway Kertosono – Surabaya*, 2016.
- [10] Ready B., Krisnamurti, and Nurtjahjaningtyas I., Analysis of slope stability in soft soil using hardening soil modeling and strengthening of bamboo mattress. *International Journal of GEOMATE*, Vol. 19, Issue. 73, 2020, pp. 226–234.
- [11] Irsyam M., Bamboo Pile-Mattress System as An Alternative of Soft Ground Improvement for Coastal Embankment in Indonesia. *Annual Lecture, Indonesian Geotechnical Society Annual Conference*, 2018.
- [12] No-name, First time in Indonesia: Bamboo mattress comes, toll roads extend. <https://indonesia.go.id/kategori/budaya/5541/pertama-di-indonesia-rakit-bambu-datang-jalan-tol-terbentang?lang=1>, Jul. 21, 2022 (in Indonesian).
- [13] Look B. G., *Handbook of Geotechnical Investigation and Design Tables*. Taylor & Francis, 2007, pp. 1-331.
- [14] Ma'ruf M. F., and Darjanto H., Back Calculation of Excessive Deformation on Deep Excavation. *Procedia Engineering*, Vol. 171, 2017, pp. 502–510.
- [15] Poulos H. G., Design Charts for Piles Supporting Embankments on Soft Clay. *Journal of Geotechnical and Geoenvironmental Engineering*, Vol. 133, No. 5, 2007, pp. 493–501.
- [16] Rai S., and Singh B., Effect of Piles on Response of Raft Foundations, *Indian*

- Geotechnical Conference, 2010, pp. 917–920.
- [17] Fagundes D. F., Almeida M. S. S., Thorel, L., and Blanc M., Load transfer mechanism and deformation of reinforced piled embankments. *Geotextiles and Geomembranes*, Vol. 45, No. 2, 2017, pp. 1–10.
- [18] Quang H. T., Amornfa K. and Tuan T. V., Piled Raft - An Effective Foundation Design Method for High-Rise Buildings in Ho Chi Minh City, Viet Nam. *International Journal of GEOMATE*, Vol. 21, Issue 87, 2021, pp. 102–109.
- [19] Modak R., and Singh B., Parametric Study of The Behavior of Large Piled Raft Foundation on Stiff Clay. *Foundation and Forensic Geotechnical Engineering*, Muthukkumaran K., Reddy C. N. V. S., Joseph A., and Senthamilkumar S. (Eds.), 2023, pp. 43–54.
- [20] De Sanctis L., and Mandolini A. Bearing Capacity of Piled Rafts on Soft Clay Soils. *Journal of Geotechnical And Geoenvironmental Engineering*, Vol. 132, 2006, pp. 1600–1610.
- [21] Wang F., Shao J., Li W., Wang Y., Wang L., and Liu H., Study on the Effect of Pile Foundation Reinforcement of Embankment on Slope of Soft Soil. *Sustainability*, Vol. 14, No. 21, 2022, pp. 14359 - 14370.
- [22] Li P. Y., Dou H. Q., Wang H., Nie W. F., and Chen, F. Q., Stability Analysis of Pile-Supported Embankments over Soft Clay Considering Soil Failure between Piles Based on Upper Bound Theorem. *Sustainability*, 2022, Vol. 14, pp. 11652 - 11668.
- [23] Kakurai M., Yamashita K., and Tomono M., Settlement behavior of piled raft foundation on soft ground. *The 8th Asian Regional Conference on Soil Mechanics and Foundation Engineering*, 1987, pp. 373–378.
- [24] Yamashita K., Yamada T., and Hamada J., Investigation of Settlement and Load Sharing on Piled Rafts by Monitoring Full-Scale Structures. *Soils and Foundations*, Vol. 51, No. 3, 2011, pp. 513–532.
- [25] Deb P., and Pal S. K., Analysis of Load Sharing Response and Prediction of Interaction Behavior in Piled Raft Foundation. *Arab J Sci Eng.*, Vol. 44, No. 10, 2019, pp. 8527–8543.
- [26] Juneja A., Tiyagi A., and Bisht R., Load Sharing in Piled Rafts, Indian Geotechnical Conference, 2013, pp. 1–9.
- [27] Ca H. V., Nguyen T. A., and Le V. U. N., 3d Finite Element Analysis of The Effect of Raft Thickness, Pile Spacing, And Pile Length on The Behavior of Piled Raft Foundation. *International Journal of GEOMATE*, Vol. 23, Issue. 98, 2022, pp. 47–56.
- [28] Oh E. Y. N., Bui M., and Balasurbamian A. S., Investigation of the Behavior of Piled Raft Foundations in Sand by Numerical Modeling. *The 19th International Offshore and Polar Engineering Conference*, 2009, pp. 230–235.
- [29] Viggiani C., Analysis and design of piled foundations. *First Arrigo Croce Lecture, Rivista Italiana di Geotecnica*, 2001, Vol. 1, pp. 47–75.
- [30] Davis B. E. H., and Poulos H. G., The Analysis of Pile Raft Systems. *Australian Geomechanics Journal*, 1972, pp. 21–27.
- [31] Akl A. Y., Mansour M. H., and Moustafa H. K., Effect of changing configurations and lengths of piles on piled raft foundation behavior. *Civil Engineering and Urban Planning: An International Journal*, Vol. 1, No. 1, 2014, pp. 49–65.
- [32] Briançon L., and Simon B., Performance of Pile-Supported Embankment over Soft Soil: Full-Scale Experiment. *Journal of Geotechnical and Geoenvironmental Engineering*, Vol. 138, No. 4, 2012, pp. 551–561.
- [33] Ma B., Li Z, Cai K., Liu M., Zhao M., Chen B., Chen Q., and Hu Z., Pile-Soil Stress Ratio and Settlement of Composite Foundation Bidirectionally Reinforced by Piles and Geosynthetics under Embankment Load. *Advances in Civil Engineering*, Vol. 2021, 2021, pp. 1–10.
- [34] Ma H., Luo Q., Wang T., Jiang H., and Lu Q., Numerical stability analysis of piled embankments reinforced with ground beams. *Transportation Geotechnics*, Vol. 26, 2021, p. 100427.