

ISSN: 2348-6988

Digital Repository Universitas Jember

# **International Journal of Electrical and Electronics Research**

**October - December 2022**

**Vol. 10 (4)**



## **IMPROVING THE SECURITY OF A DATA COMMUNICATION SYSTEM USING ENCRYPTED TECHNOLOGY**

Eze Cletus Elijah, Alor M.O.....1-16

## **Fractional Integral Curves of Some Fractional Differential Equations**

Chii-Huei Yu.....17-22

## **Design of Lighting System and Watering Automation Based Internet of Things with Message Queuing Telemetry Transport Protocol and Framework Flutter**

Ardianto Syaifur Rohman, Bambang Sujanarko, Bambang Sri Kaloko.....23-32



## Editorial Board Members

Name	Designation	University
IJMPSR	[A]. International Journal Of Mathematics And Physical Sciences Research (IJMPSR)	IJMPSR
1. Mr. DONNEL JAY EBRON TAMBIS	Master Of Arts In Education (Mathematics)	Naval State University (NSU)
2. Dr. Youssef Elmahroug	Researcher, Faculty Of Sciences Of Tunis, EL Manar University Campus, Tunis.	PhD, Particle Physics And High Energy, Faculty Of Sciences Of Tunis, Tunisia And Cotutelle With The Institute Of Nuclear Physics Of Lyon, France.
3. Dr. ODULARU, AYODELE TEMIDAYO	Faculty Of Science And Agriculture, University Of Fort Hare, South Africa	PhD, Faculty Of Science And Agriculture, University Of Fort Hare, South Africa
4. Prof. Dr. AMER A. TAQA	PROFESSOR, DEPARTMENT OF DENTAL BASIC SCIENCE COLLEGE OF DENTISTRY/MOSUL UNIVERSITY/IRAQ	PhD In Inorganic Chemistry
5. Dr. Mehsin Jabel Atteya	Assistant Professor, Mathematics	M.Sc. Degree: Al-Mustansiriyah University, College Of Education-Department Of Mathematics, Iraq
6. Dr. Qasem M. Al-Mdallal	"Associate Professor Of Mathematics Department Of Mathematical Sciences United Arab Emirates University Al-Ain, UAE"	PhD, Mathematics, Memorial University Of Newfoundland, Canada
7. Dr. Walid Ali Ahmed Hassan Rahoma	Associate Prof.& Researcher, Dept. Of Astronomy And Space Science, Cairo University	PhD, Astronomy, Cairo University, Faculty Of Science, Department Of Astronomy And Meteorology
8. Dr. Faisal Hussain Nesayef	Ph.d Pure Mathematics University Of Birmingham UK	Faculty Of Science, Department Of Mathematics, University Of Kirkuk, Kirkuk, Iraq
9. Dr. Ayodele Temidojo	Phd, PGDE, M.sc	University Of Fort Hare South Africa
10. Dr. Adrian Nicolae Branga	Phd.Mathematics BabeE-Bolyai University Of Cluj-Napoca	Department Of Mathematics And Information Lucian Blaga University Of Sibiu Romania
11. Dr. DIOBEIN FLORES	Doctor Of Public Administration-Master Of Education Teaching Science	Member - Association Science Education Of The Philippines Science Club Advisers Association Of The Philippines
12. Prof. JOVENIL R. BACATAN	ASSOCIATE PROFESSOR, UM Peñaplata College   Island Garden City Of Samal, Davao Del Norte	Doctor Philosophy-Educational Management (On-going) Holy Cross Of Davao College
IJIRI	[B]. International Journal Of Interdisciplinary Research And Innovations (IJIRI)	IJIRI
1. Dr. EMMIE M. CABANLIT, ED.D.	Associate Professor III, University Of Southeastern Philippines (USEP)	PhD, University Of Southeastern Philippines, Davao City
2. Dr. Esi Marius Costel	PhD Lecturer, Stefan Cel Mare University Of Suceava, Romania	Phd, Ontology And Science Philosophy, Al.I Cuza University, Faculty Of Philosophy
3. Dr. JEDER Daniela	"Associate Professor , Faculty Of Sciences Of Education, University ""Stefan Cel Mare" " Suceava "	PhD, Interdisciplinary Study PEDAGOGY ETHICS, University
4. Dr. Yeoh Kar Kheng	Senior Lecturer, School Of Chemical Sciences, Universiti Sains Malaysia, Malaysia.	D.Phil., University Of Oxford, United Kingdom.
5. Prof. (Dr.) Zainal Arifin Ahmad	Professor, School Of Materials And Mineral Resources Engineering, Universiti Sains Malaysia, MALAYSIA.	PhD, MSc, BAppSc(Hons), Malayasia.
6. Dr. Hooi-Ling Lee	Senior Lecturer, School Of Chemical Sciences, Universiti Sains Malaysia, Malaysia.	PhD (Surface Science), School Of Physical Sciences, Dublin City University, Ireland.
7. Dr. Alagbe Olujimi John	Doctor Of Theology (Ph.D)	United Marina Farms Limited Along Airport Road Kutungare Kaduna
8. Mr. Samantha Ilangakoon	B.A, M.A, Mphil	Buddhist And Pali University Of Sri Lanka
9. Dr. Asma Irshad	M.B.B.S Ahmadu Bello University Teaching Hospital, Nigeria	Ahmadu Bello University Teaching Hospital, Nigeria

10. Prof. Dr. Bulent Acma	Ph.D. Economics, Regional And Urban Development, Istanbul University, Department Of Economics, Istanbul	Anadolu University, Faculty Of Economics, Unit Of Southeastern Anatolia Project, (GAP), Eskisehir/TURKEY
11. Dr. Adam Dawria Ibrahim	Ph.D In Public Health	Shendi University- Faculty Of Public Health
12. Dr. Adrian Nicolae Branga	Phd. Mathematics Babes - Bolyai University Of Cluj-Napoca	Department Of Mathematics And Information Lucian Blaga University Of Sibiu Romania
13. Dr. DIDBEIN FLORES	Doctor Of Public Administration-Master Of Education Teaching Science	Member - Association Science Education Of The Philippines Science Club Advisers Association Of The Philippines
14. Dr. Roger D. Posadas	Executive Director. Research And Innovation Center Lyceum Of The Philippines University- Cavite	Philippines University, Philippines.
IJTPD	[C]. International Journal Of Thesis Projects And Dissertations (IJTPD)	IJTPD
1. Dr Madhavi Sripathi	Associate Professor, Seshadri Rao Gudlavalkeru Engineering College	PhD, Seshadri Rao Gudlavalkeru Engineering College
2. Dr. WENDELL L. GALAPATE	Associate Professor/Program Chair, & Quality Internal Auditor SIHTM Department	Ph.D. IHM, Lyceum Of The Philippines University Manila
3. Prof. JOVENIL R. BACATAN	ASSOCIATE PROFESSOR, UM Peñaplata College   Island Garden City Of Samal, Davao Del Norte	Doctor Philosophy-Educational Management (On-going) Holy Cross Of Davao College
8. Dr. Esi Marius Costel	PhD Lecturer, Stefan Cel Mare University Of Suceava, Romania	Phd, Ontology And Science Philosophy, AI.I Cuza University, Faculty Of Philosophy
9. Dr. JEDER Daniela	"Associate Professor , Faculty Of Sciences Of Education, University ""Stefan Cel Mare" " Suceava "	PhD, Interdisciplinary Study PEDAGOGY ETHICS, University
10. Dr Mohamed Saber Gad	Researcher, Mechanical Engineering Department, National Research Centre, Egypt	Ph.D., Mechanical Engineering, Faculty Of Engineering, AL-Azhar University
11. Dr. MARGARET NDUTA GITHA	"HOD, Department At Regina Pacis University College-Constitute College Of Catholic University Of Eastern Africa"	Ph D Community Health And Development
12. Dr. Uqbah Bin Muhammad Iqbal	Universiti Kebangsaan Malaysia, SCHOOL OF HISTORY, POLITICS AND STRATEGY	PhD, History, National University Of Malaysia
13. Prof. (Dr.) M.S. Ayyat	Professor, Department Of Animal Production, University Of Zagazig, Zagazig, Egypt.	Ph.D., Animal Production, Leningrad Agriculture Institute, Leningrad, USSR.
14. Dr. Lee Chee Keong	Senior Lecturer, Bioprocess Technology Division, School Of Industrial Technology, Universiti Sains Malaysia, Malaysia.	Ph.D., Industrial Biotechnology, University Sains Malaysia, Malaysia.
15. Dr. Muhammad Faizal Bin A. Ghani	Associate Prof., Department Of Educational Management, Planning And Policy, Faculty Of Education, University Of Malaya, Malaysia.	PhD (UM), University Of Malaya, Malaysia.
16. Mr. P. Khandelwal	M. Tech. (C. S.), M. E. (High Voltage Engineering), Jabalpur Engineering College, Jabalpur, India.	L.LB., Lucknow University, Lucknow, India.
17. Dr. Alagbe Olujimi John	Doctor Of Theology (Ph.D)	United Marina Farms Limited Along Airport Road Kutungare Kaduna
18. Mr. Samantha Ilangakoon	B.A, M.A, Mphil	Buddhist And Pali University Of Sri Lanka
19. Dr. Ayodele Temidoyo	Phd, PGDE, M.sc	University Of Fort Hare South Africa
20. Dr. Kenneth Kiplangat Rono	PHD . Planning And Economics Of Education	Kenyatta University
IJSSHR	[D]. International Journal Of Social Science And Humanities Research (IJSSHR)	IJSSHR
1. Dr Madhavi Sripathi	Associate Professor, Seshadri Rao Gudlavalkeru Engineering College	PhD, Seshadri Rao Gudlavalkeru Engineering College
2. Dr. WENDELL L. GALAPATE	Associate Professor/Program Chair, & Quality Internal Auditor SIHTM Department	Ph.D. IHM, Lyceum Of The Philippines University Manila
3. Prof. JOVENIL R. BACATAN	ASSOCIATE PROFESSOR, UM Peñaplata College   Island Garden City Of Samal, Davao Del Norte	Doctor Philosophy-Educational Management (On-going) Holy Cross Of Davao College

5. Dr. Muhammad Faizal Bin A. Ghani	Associate Prof., Department Of Educational Management, Planning And Policy, Faculty Of Education, University Of Malaya, Malaysia.	PhD (UM), University Of Malaya, Malaysia.
6. Dr. Thomas Babalis	Professor, Faculty Of Primary Education, University Of Athens, Greece.	Ph.d. Degree, University Of Athens, Greece.
7. Mr. Samantha Ilangakoon	B.A, M.A, M Phil	Buddhist And Pali University Of Sri Lanka
8. Prof. Dr. Bulent Acma	Ph.D. Economics, Regional And Urban Development, Istanbul University, Department Of Economics, Istanbul	Anadolu University, Faculty Of Economics, Unit Of Southeastern Anatolia Project, (GAP), Eskisehir/TURKEY
9. Prof. Randel Estacio	Master Of Arts In Education Science ( Mat- Science), Master Of Science Biology (Ms.Bio), Bachelor Of Science In Education Major In General Science	Quezon City Polytechnic University
10. Prof. Thouqan Saleem	PhD .[Methods Of Instrucation And Curricula / English ]	Najran University /Kingdom Of Saudi Arabia
11. Dr. DIDBEIN FLORES	Doctor Of Public Administration-Master Of Education Teaching Science	Member - Association Science Education Of The Philippines Science Club Advisers Association Of The Philippines
12. Dr. Roger D. Posadas	Executive Director. Research And Innovation Center Lyceum Of The Philippines University- Cavite	Philippines University, Philippines.
13. Dr. Raymond A, Ezejiolor	Lecturer, Department Of Accountancy, Nnamdi Azikiwe University	Ph.D., Nnamdi Azikiwe University, Awka
14. Dr. Tina Khandelwal	Consultant	Ph.D, Management, AKTU
15. Dr. AMELIE L. CHICO	FELLOW ROYAL INSTITUTION OF SINGAPORE (FRIM)	Ph.D. In Business Management, University Of Immaculate Concepcion, Davao City, Philippines
IJMCI	[E]. International Journal Of Management And Commerce Innovations (IJMCI)	IJMCI
1. Dr. P. ARUNACHALAM	Assistant Professor & Head, Department Of Economics, Periyar University	M.A., M. Phil., SET, PhD.
2. Dr. Raymond A, Ezejiolor	Lecturer, Department Of Accountancy, Nnamdi Azikiwe University	Ph.D., Nnamdi Azikiwe University, Awka
3. Dr. Hermanto Yaputra	Lecturer At University Of Trisakti, Indonesia	Doctoral Degree, University Of Trisakti, Jakarta, Indonesia
4. Dr. Tina Khandelwal	Consultant	Ph.D, Management, AKTU
5. Dr. AMELIE L. CHICO	FELLOW ROYAL INSTITUTION OF SINGAPORE (FRIM)	Ph.D. In Business Management, University Of Immaculate Concepcion, Davao City, Philippines
6. Dr Madhavi Sripathi	Associate Professor, Seshadri Rao Gudlavalkeru Engineering College	PhD, Seshadri Rao Gudlavalkeru Engineering College
7. Dr. WENDELL L. GALAPATE	Associate Professor/Program Chair, & Quality Internal Auditor SIHTM Department	Ph.D. IHM, Lyceum Of The Philippines University Manila
8. Dr. Mehl S. Patel	Assistant Professor, Sardar Patel College Of Administration And Management	Ph. D In Management With IT, PAHER University, Udaipur
9. Dr. Keon-Hyung Lee	Associate Professor, Public Administration And Public Health, Florida State University.	Ph.D., Ph.D., University Of Southern California, School Of Public Policy, Planning, And Development, Los Angeles.
10. Dr. Nik Ab Halim Bin Nik Abdullah	Senior Lecturer, School Of International Studies, Universiti Utara Malaysia, Kedah, Malaysia.	PhD. International Logistics Management, University Of Southern Queensland, Australia.
12. Dr. Yagoub Elryah	Research Associate, Research Economic Forum (REF), Xiamen University	PhD From Xiamen University
13. Dr. Uqbah Bin Muhammad Iqbal	Universiti Kebangsaan Malaysia, SCHOOL OF HISTORY, POLITICS AND STRATEGY	PhD, History, National University Of Malaysia
14. Dr. Ebrahim Nohani	Assistant Professor And Faculty Member At Islamic Azad University, Dezful Branch, Department Of Hydraulic Structures, Dezful, IRAN	Ph.D. In Hydraulic Structures, Islamic Azad University, Iran
15. Dr. Fatemeh Yarkarami	Islamic Azad University Of Kermanshah, Iran	Islamic Azad University Of Kermanshah, Iran
16. Prof. Dr. Bulent Acma	Ph.D. Economics, Regional And Urban Development,	Anadolu University, Faculty Of Economics, Unit Of

	Istanbul University, Department Of Economics, Istanbul	Southeastern Anatolia Project, (GAP), Eskisehir/TURKEY
17. Dr. Roger D. Posadas	Executive Director, Research And Innovation Center Lyceum Of The Philippines University- Cavite	Philippines University, Philippines.
IJLSR	[F]. International Journal Of Life Sciences Research (IJLSR)	IJLSR
1. Dr. Roberta Manuela Moretti	Researcher, Applied Biology, Department Of Pharmacological Sciences And Biomolecular, University Of Milan, Italy.	Ph.D., Endocrine And Metabolic Sciences, University Of Milan, Italy.
2. Prof. (Dr.) M.S. Ayyat	Professor, Department Of Animal Production, University Of Zagazig, Zagazig, Egypt.	Ph.D., Animal Production, Leningrad Agriculture Institute, Leningrad, USSR.
3. Dr. Yeoh Kar Kheng	Senior Lecturer, School Of Chemical Sciences, Universiti Sains Malaysia, Malaysia.	D.Phil., University Of Oxford, United Kingdom.
4. Dr. Lee Chee Keong	Senior Lecturer, Bioprocess Technology Division, School Of Industrial Technology, Universiti Sains Malaysia, Malaysia.	Ph.D., Industrial Biotechnology, University Sains Malaysia, Malaysia.
5. Dr. Alagbe Olujimi John	Doctor Of Theology (Ph.D)	United Marina Farms Limited Along Airport Road Kutungare Kaduna
6. Dr. Adam Dawria Ibrahim	Ph.D In Public Health	Shendi University- Faculty Of Public Health
7. Dr. Ayodele Temidoyo	Phd, PGDE, M.sc	University Of Fort Hare South Africa
8. Dr. DIDBEIN FLORES	Member - Association Science Education Of The Philippines Science Club Advisers Association Of The Philippines	Doctor Of Public Administration-Master Of Education Teaching Science
9. DR. RANJEETA CHATTERJEE	Asst. Professor, Department Of Zoology, Prof. Ramkrishna More ACS College, Akurdi, Pune.	Doctor Philosophy-Educational Management (On-going) Holy Cross Of Davao College
10. Dr. Roberta Manuela Moretti	Researcher, Applied Biology, Department Of Pharmacological Sciences And Biomolecular, University Of Milan, Italy.	Ph.D., Endocrine And Metabolic Sciences, University Of Milan, Italy.
11. Prof. (Dr.) M.S. Ayyat	Professor, Department Of Animal Production, University Of Zagazig, Zagazig, Egypt.	Ph.D., Animal Production, Leningrad Agriculture Institute, Leningrad, USSR.
12. Dr. Yeoh Kar Kheng	Senior Lecturer, School Of Chemical Sciences, Universiti Sains Malaysia, Malaysia.	D.Phil., University Of Oxford, United Kingdom.
13. Dr. Pablito Macapugay Magdalita	Professor, Crop Science Cluster & Institute Of Plant Breeding, College Of Agriculture, University Of The Philippines	Doctor Of Philosophy, Department Of Agriculture, The University Of Queensland, Brisbane, Australia
14. Dr. Dhruva Pathak	Post Doc , Department Of Anatomy And Neurobiology, The University Of Tennessee Health Science Center	PhD In Biological Science, University Of Belgrade, Serbia.
15. Dr. Mohammad Javed Ansari	Head Of The Department, Department Of Pharmaceutics, College Of Pharmacy Prince Sattam Bin Abdulaziz University Al-kharj, Saudi Arabia	Ph.D. Pharmaceutical Sciences / Pharmaceutical Medicine, Year, College Of Pharmacy, Jamia Hamdard, University
16. Dr. Roger D. Posadas	Executive Director. Research And Innovation Center Lyceum Of The Philippines University- Cavite	Philippines University, Philippines.
17. Dr. Mokhtar Nosrati	Researcher, Zistfile Bioinformatics Center	Ph.D. University Of Isfahan
18. Dr. MARYAM	Researchers	Doctor Of Philosophy Fisheries Science And Aquaculture Aligarh Muslim University
IJHS	[G]. International Journal Of Healthcare Sciences (IJHS)	IJHS
1. Dr. KAPIL SHARMA	Professor And HOD, NPCC Programme	PhD. (Nursing), SJJT University, Rajasthan
2. Prof. Dr. AMER A. TAQA	PROFESSOR, DEPARTMENT OF DENTAL BASIC SCIENCE COLLEGE OF DENTISTRY/MOSUL UNIVERSITY/IRAQ	PhD In Inorganic Chemistry
3. Dr. Dhruva Pathak	Post Doc , Department Of Anatomy And Neurobiology, The University Of Tennessee Health Science Center	PhD In Biological Science, University Of Belgrade, Serbia.
4. Dr. MARGARET NDUTA GITHA	"HOD, Department At Regina Pacis University College- Constitute College Of Catholic University Of Eastern	Ph D Community Health And Development

	Africa"	
5. Dr. Chona Q. Sarmiento	"Research Director, Research Development And Evaluation Center, Western Mindanao State University, Philippines "	PhD, Science Education, Biology
6. Dr. Mohammad Javed Ansari	Head Of The Department, Department Of Pharmaceutics, College Of Pharmacy Prince Sattam Bin Abdulaziz University Al-kharj, Saudi Arabia	Ph.D. Pharmaceutical Sciences / Pharmaceutical Medicine, Year, College Of Pharmacy, Jamia Hamdard, University
7. Dr. Yeoh Kar Kheng	Senior Lecturer, School Of Chemical Sciences, Universiti Sains Malaysia, Malaysia.	D.Phil., University Of Oxford, United Kingdom.
8. Mr. P. Khandelwal	M. Tech. (C. S.), M. E. (High Voltage Engineering), Jabalpur Engineering College, Jabalpur, India.	L.LB. (P), Lucknow University, Lucknow, India.
9. Dr. Asma Irshad	M.B.B.S Ahmadu Bello University Teaching Hospital, Nigeria	Ahmadu Bello University Teaching Hospital, Nigeria
10. Dr. Karen Clark	Faculty, School Of Nursing, University Of Maryland School Of Nursing. The Universities At Shady Grove.	PhD, Nursing, George Mason University, Fairfax, Virginia.
11. Dr. Adam Dawria Ibrahim	Ph.D In Public Health	Shendi University- Faculty Of Public Health
IJERR	[H]. International Journal Of Engineering Research And Reviews (IJERR)	IJERR
1. Dr. Rambabu Busi	Professor And Head, Dept Of EIE, Lakireddy Bali Reddy College Of Engineering, Mylavaram	Doctor Of Philosophy (Ph.D.) In Microelectronics
2. Dr. HARPAL	Associate Professor	Ph.D, Shri Venkateshwara University
3. Dr. Ahmed Abdelraheem Farghaly Elkhodary	Professor, Faculty Of Industrial Education, Sohag University	PhD In Structural Engineering, Civil Engineering Department - College Of Engineering, Assiut University
4. Dr. Ebrahim Nohani	Assistant Professor And Faculty Member At Islamic Azad University, Dezful Branch, Department Of Hydraulic Structures, Dezful, IRAN	Ph.D. In Hydraulic Structures, Islamic Azad University, Iran
5. Prof. (Dr.) Zainal Arifin Ahmad	Professor, School Of Materials And Mineral Resources Engineering, Universiti Sains Malaysia, MALAYSIA.	PhD, MSc, BAppSc(Hons), Malaysia.
6. Dr. Patrizia Trovalusci	Professor, Department Of Structural Engineering And Geotechnics, Sapienza, University Of Rome, Rome.	PhD, Structures And Architecture, (History Of Building Sciences And Techniques), University Of Florence, Italy.
7. Mr. P. Khandelwal	M. Tech. (C. S.), M. E. (High Voltage Engineering), Jabalpur Engineering College, Jabalpur, India.	L.LB. (P), Lucknow University, Lucknow, India.
8. Prof. Jay Chatterjee	Emeritus Professor Of Architecture And Planning At The University Of Cincinnati, Ohio, U.S.	School Of Architecture And Interior Design M.Arch. (Urban Design), Harvard University.
9. Dr. Resat Atalay	Lecturer, Institute Of Earthquake Engineering And Disaster Management, Istanbul Technical University	Istanbul Technical University
10. Dr. Adrian Nicolae Branga	Phd.Mathematics Babes - Bolyai University Of Cluj-Napoca	Department Of Mathematics And Information Lucian Blaga University Of Sibiu Romania
IJMIT	[I]. International Journal Of Mechanical And Industrial Technology (IJMIT)	IJMIT
1. Dr DIMITRIOS E. MAZARAKOS	Experienced Research Associate, APPLIED MECHANICS LABORATORY, UNIVERSITY OF PATRAS	PhD. Subsea Engineering, UNIVERSITY OF PATRAS
2. Dr Mohamed Saber Gad	Researcher, Mechanical Engineering Department, National Research Centre, Egypt	Ph.D., Mechanical Engineering, Faculty Of Engineering, AL-Azhar University
3. Prof. (Dr.) Mariatti Jaafar	Program Chairman, Materials Engineering, School Of Materials & Mineral Resources Eng.,USM Eng. Campus,Malaysia.	P.hd., Universiti Sains Malaysia, Malaysia.; Degree Of Licentiate, Royal Institute Of Technology, Degree Of Licentiate, Stockholm, Sweden.
4. Mr. P. Khandelwal	M. Tech. (C. S.), M. E. (High Voltage Engineering), Jabalpur Engineering College, Jabalpur, India.	L.LB. (P), Lucknow University, Lucknow, India.
5. Dr. Adrian Nicolae Branga	Phd.Mathematics Babes - Bolyai University Of Cluj-Napoca	Department Of Mathematics And Information Lucian Blaga University Of Sibiu Romania
IJEER	[J]. International Journal Of Electrical And Electronics Research (IJEER)	IJEER

1. Dr. Rambabu Busi	Professor And Head, Dept Of EIE, Lakireddy Bali Reddy College Of Engineering, Mylavaram	Doctor Of Philosophy (Ph.D.) In Microelectronics
2. Dr. HARPAL	Associate Professor	Ph.D, Sri Venkateshvara Unniversity
3. Dr. Zia Saquib	Executive Director, C-DAC Mumbai	PhD, National Institute Of Technology, Surat
4. Dr. Rohollah. Abdollahi	Faculty The Electrical Eng. Department, Shahab-e-Danesh Institute Of Higher Education, Qom, Iran	PhD, Iran University Of Science And Technology, Tehran, Iran
5. Mr. P. Khandelwal	M. Tech. (C. S.), M. E. (High Voltage Engineering), Jabalpur Engineering College, Jabalpur, India.	L.LB. (P), Lucknow University, Lucknow, India.
6. Dr. Adrian Nicolae Branga	Phd.Mathematics Babes - Bolyai University Of Cluj-Napoca	Department Of Mathematics And Information Lucian Blaga University Of Sibiu Romania
IJCSITR	[K]. International Journal Of Computer Science And Information Technology Research (IJCSITR)	IJCSITR
1. Dr. Mehul S. Patel	Assistant Professor, Sardar Patel College Of Administration And Management	Ph. D In Management With IT, PAHER University, Udaipur
4. Prof. DR. SAN SAN TINT	Professor, Head Of Department, Computer Hardware Technology Department, Computer University (Mandalay), The Republic Of The Union Of Myanmar	Ph.D, Information Technology, Myanmar
5. Dr Zia Saquib	Executive Director, C DAC Mumbai	PhD, National Institute Of Technology, Surat
6. Dr. Alagbe Olujimi John	Doctor Of Theology (Ph.D)	United Marina Farms Limited Along Airport Road Kutungare Kaduna
7. Dr. Resat Atalay	Lecturer, Institute Of Earthquake Engineering And Disaster Management, Istanbul Technical University	Istanbul Technical University
8. Dr. Adrian Nicolae Branga	Phd.Mathematics Babes - Bolyai University Of Cluj-Napoca	Department Of Mathematics And Information Lucian Blaga University Of Sibiu Romania
9. Dr. MAKERI AJIJI	NCE,HD,HND,Bsc, Msc, Phd Information Tecnology	Institute Of Governance And Management Nigeria
10. Dr. Roger D. Posadas	Executive Director. Research And Innovation Center Lyceum Of The Philippines University- Cavite	Philippines University, Philippines.
IJCSEER	[L]. International Journal Of Civil And Structural Engineering Research (IJCSEER)	IJCSEER
1. Dr. Daniele Pellegrini	External Lecturer, Department Of Energy, System, Land And Buildings Engineering, Pisa University, Italy.	PhD, Sciences And Techniques Of Civil Engineering, Disciplinary Scientific Field ICAR09, Pisa University, Graduate School Of Engineering, Leonardo Da Vinci.
2. Dr DIMITRIOS E. MAZARAKOS	Experienced Research Associate, APPLIED MECHANICS LABORATORY, UNIVERSITY OF PATRAS	PhD. Subsea Engineering, UNIVERSITY OF PATRAS
3. Dr. Ahmed Abdelraheem Farghaly Elkhodary	Professor, Faculty Of Industrial Education, Sohag University	PhD In Structural Engineering, Civil Engineering Department - College Of Engineering, Assiut University
4. Dr. A.B.M. Amrul Kaish	Graduate Research Assistant, Sustainable Construction Materials & Building System, Faculty Of Engineering & Built Environment, Universiti Kebangsaan Malaysia	Ph D, Civil & Structural Engineering, Universiti Kebangsaan Malaysia (UKM), Malaysia
5. Dr. Ebrahim Nohani	Assistant Professor And Faculty Member At Islamic Azad University, Dezful Branch, Department Of Hydraulic Structures, Dezful, IRAN	Ph.D. In Hydraulic Structures, Islamic Azad University, Iran
6. Prof. Jay Chatterjee	Emeritus Professor Of Architecture And Planning At The University Of Cincinnati, Ohio, U.S.	School Of Architecture And Interior Design M.Arch. (Urban Design), Harvard University; MRP, University Of North Carolina; Certificate, Tropical Architecture, AA School; B.Arch., Indian Institute Of Technology, India.
7. Dr. Resat Atalay	Lecturer, Institute Of Earthquake Engineering And Disaster Management, Istanbul Technical University	Istanbul Technical Universt



# Design of Lighting System and Watering Automation Based Internet of Things with Message Queuing Telemetry Transport Protocol and Framework Flutter

Ardianto Syaifur Rohman<sup>1</sup>, Bambang Sujanarko<sup>2</sup>, Bambang Sri Kaloko<sup>3</sup>

<sup>1,2,3</sup>Department of Electrical Engineering, Jember University, Jember, Indonesia

DOI: <https://doi.org/10.5281/zenodo.7347542>

Published Date: 22-November-2022

---

**Abstract:** The management of electricity consumption for lamps and water tanks generally relies on a kWh meter, so it is still not effective because it can only monitor and limit electricity usage, not being able to turn off pumps and unused lights. These problems can be overcome with the Internet of Things, which is able to connect equipment through the internet network. The process requires a communication protocol system, which is efficient in terms of bandwidth, latency, and power consumption. The communication protocol model used in this study is Message Queuing Telemetry Transport, considering that this protocol can connect to slow networks. The test results show that the Message Queuing Telemetry Transport (MQTT) application has a better performance on the lighting and watering automation system, which is implemented on a mobile application using the Flutter framework to receive and display high-load garden light control, waterpump control and underground reservoir water level monitoring. The calibration results show that the HYSRF05 sensor can work well in the range of 50-150 cm, with a maximum relative error of 0.36%. The smallest distance change that can be detected by the sensor is 0.04 cm with a maximum relative error of 0.05%. With the magnitude of the error obtained, it can be said that the sensor is suitable for use as a water level detector in an underground reservoir water level monitoring system. The power consumption for lighting and water pumps shows that the design of this system has an impact on power savings of 118.03 kWh. With the Flutter framework, a Mobile Application was built to manage and handle underground reservoir water level monitoring system data, so that users can set conditions to notify users about water level thresholds, use of lighting devices and water pumps through a Mobile Application that is equipped with a Notification feature that is integrated in real-time.

**Keywords:** Internet Of Things (IOT), MQTT, Lighting and Waterpump Control, Underground Water Reservoir Monitoring, Flutter, Mobile Apps.

---

## I. INTRODUCTION

Difficulties in the process of controlling electrical equipment for office building operators are due to the large area of the building associated with the process of controlling the switch from electrical devices in buildings which are generally still manual, so it takes a long time to activate electronic devices inside the building. In addition, due to the decline in human mobility during the pandemic for work and other activities, this has resulted in an increasing demand for remote control and monitoring technology for office buildings such as monitoring and controlling electronic devices [2]. Management of electrical energy consumption in usage is not enough just to use a kWh meter, because using a kWh meter is only in charge of monitoring and limiting overall electricity use. Therefore, awareness is needed to really save in the use of electrical energy. Electrical energy management can be done by looking at the consumption of electrical energy and then managing unused electronic equipment so that the cost of using electrical energy does not increase.

To solve the problem, there is a proposition for a smart building solution that enables remote monitoring and control of devices in the office building sector to identify manual or automated use of devices and control devices within the building. Smart home as an environment equipped with advanced intelligence technology that manipulates and responds according to the wishes of the occupants of the house [3]. The Internet of things (IoT) is becoming a technology consisting of a large number of different devices with diverse processing, sensing, driving, and communicating capabilities. Therefore, various new automation controls in the IoT field are being developed in many variations to make it easier for residents in the IoT environment. There are many data communication controls used in IoT technology such as: HTTP (HyperText Transfer Protocol), MQTT (Message Queuing Telemetry Transport) and CoAp (Constrained Application Protocol) [4].

One of the machine to machine (M2M) communication protocols that will be discussed in this study is MQTT. MQTT is a TCP-based protocol developed by IBM [5] with a publish/subscribe interaction pattern, which consists of one broker server and two types of clients called Publisher and Subscriber. Brokers act as intermediaries for messages sent between Publisher and Subscriber clients with special topics [6].

So, this paper presents the implementation of Design Lighting and Watering Automation System with Message Queuing Telemetry Transport Protocol and Framework Flutter. With the MQTT data communication protocol for IoT Applications in an intelligent integration based environment that supports an economical monitoring system using an ESP8266 NodeMCU connected to an ultrasonic sensor and a 4 channel switching driver connected to each other on the Mobile Application. ESP8266 collects data from sensors and publishes it to the MQTT Broker and also we implement water level monitoring and garden light control using a Mobile App with Flutter framework which integrates with MQTT and retrieves sensor data to display it in the form of animated, text and graphical user interfaces.

## II. METHODOLOGY

### A. Purpose and Contribution

The main objective of this research is to design and implement smartbuilding solutions at PT. Graha Sarana Duta Jember building facility uses ESP8266 with the MQTT data communication protocol, for monitoring the height of underground water reservoirs and remotely controlling the garden lighting system. With the aim of streamlining operational expenses, accelerating and facilitating building operators in monitoring the operational activities of building infrastructure.

### B. System Architecture

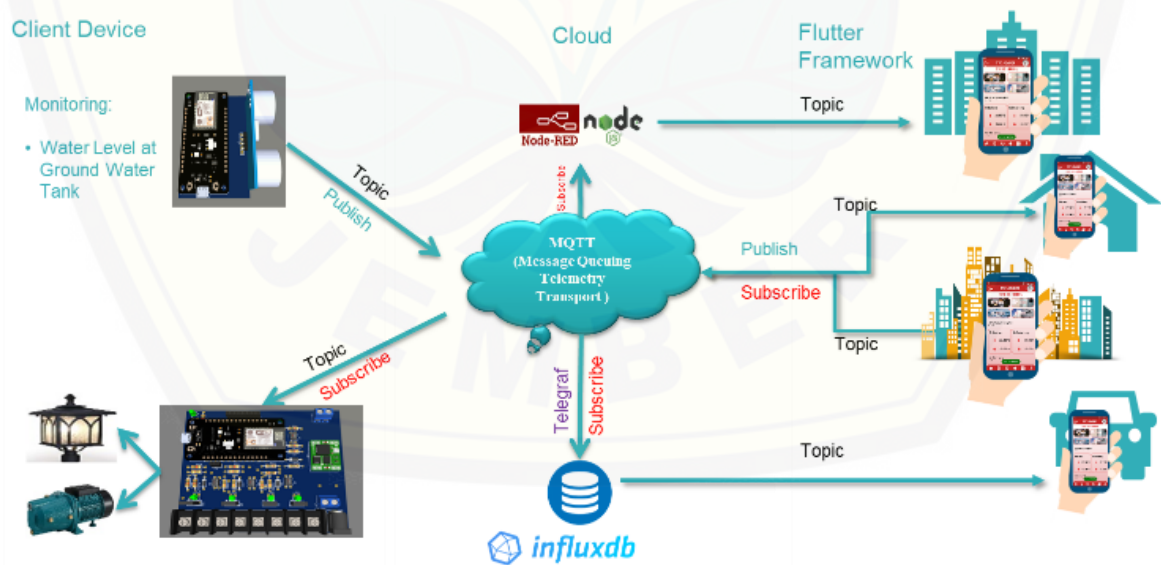
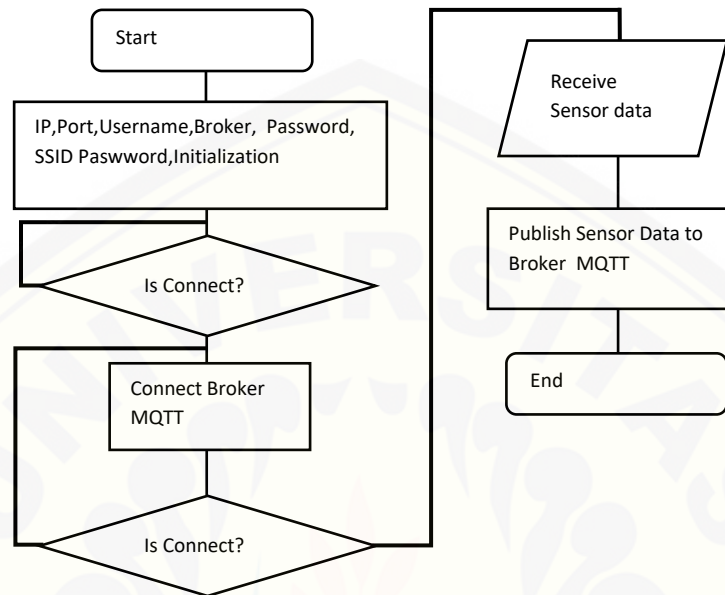

**Figure 1. System Architecture**

Figure 1 shows the proposed system architecture for the Nodemcu ESP8266 smartbuilding with MQTT and a custom application. The smartbuilding automation application runs on the Broker HiveMQ Cloud data communication protocol as a gateway to control various devices embedded with ultrasonic sensors HYSRF05 and trigger relays and contactors in real time.

**C. MQTT Messasging Protocols**

MQTT (Message Queue Telemetry Transport) is a publish/subscribe based communication protocol. The MQTT client has a very small memory size, is light and efficient, requires minimal resources so that it can be used on even small microcontrollers. MQTT message headers are small, optimizing network bandwidth. The data sent is a minimum size of 1 kb. MQTT two-way communication enables device-to-cloud and cloud-to-device messaging. It can support less reliable networks, so this very useful advantage is useful even in slow network conditions. MQTT security makes it easy to encrypt messages using TLS and authenticate clients using modern authentication protocols, such as OAuth. (<https://mqtt.org/>).



**Figure 2. Flowchart MQTT Publisher**

Explanation of Figure 2 is the initialization of IP, Port, Username and Password of MQTT Broker on ESP8266. Initialize SSID, WLAN Password used. Next, the WLAN and MQTT Broker connection authentication process based on the initialized data. Data is received by ESP8266 and then published to MQTT Broker. The process of publishing data will repeat itself every time with a delay in the program.

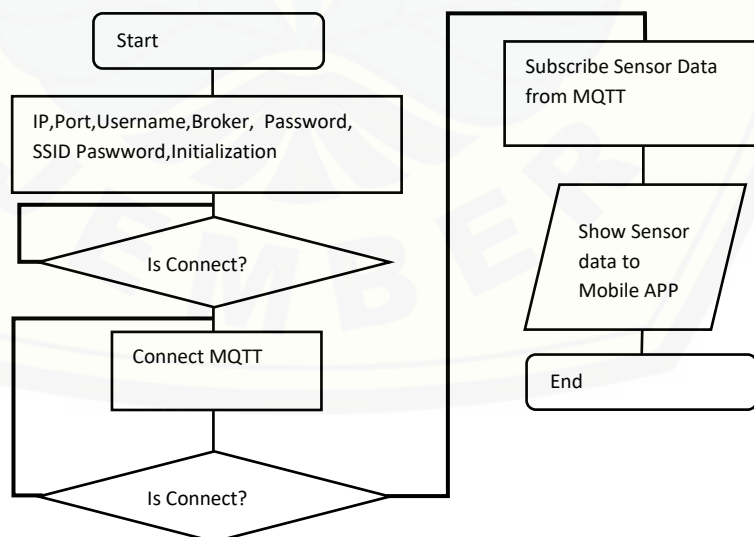

**Figure 3. Flowchart MQTT Subscriber**

Explanation of Figure 3 is the initialization of the IP, Port, Username and Password of the MQTT Broker on the ESP8266 Pi. Initialize SSID, WLAN Password used. Next, the WLAN and MQTT Broker connection authentication process based on the initialized data. Subscription data from MQTT Broker and then received to the Mobile application. Subscribing the data process will repeat at any time with a program delay.

**D. Driver Switching for Lighting and Water Pump Control**

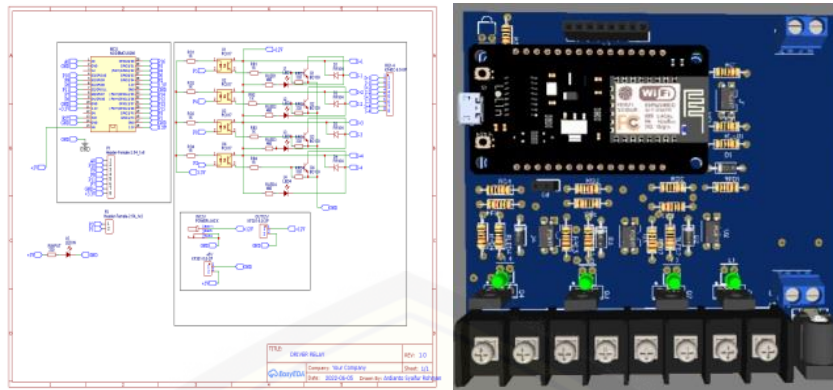

**Figure 4. Driver Switching for Lighting and Water Pump Control**

Figure 4 shows the relay driver design for lighting and water pump control integrated with the NODEMCU ESP8266 controller with an application interface schematic created using flutter. The Relay Driver functions as a breaker or connector for the flow of electric current which is controlled by providing a certain voltage and current to the coil. In this circuit, a DC relay is used with a coil voltage of 12 Volt DC and a current treated of about 20 – 30 milli Ampere. Therefore, in general we cannot directly connect the NodeMCU output to the relay because the current is not large enough. Therefore, it is necessary to use a driver as a current amplifier which is usually a transistor.

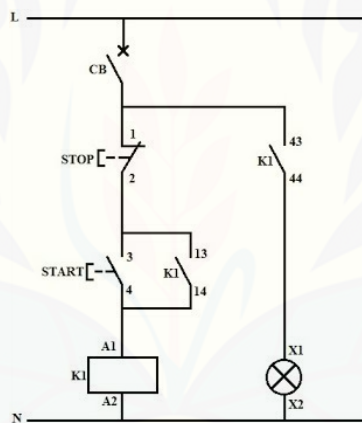

**Figure 5. Self Holding Contactor**

Figure 5 is a self holding contactor circuit with NO and NC relays switches. This self holding contactor holding circuit is commonly used in motor control, motor starter circuits such as DOL starters, star delta starters, but we apply this application to control lighting with higher loads using 3 phase magnetic contactors. The main purpose of this self-holding circuit is to keep the magnetic contactor ON even after removing the relay from the NO relay.

**E. Shield HYSRF05**

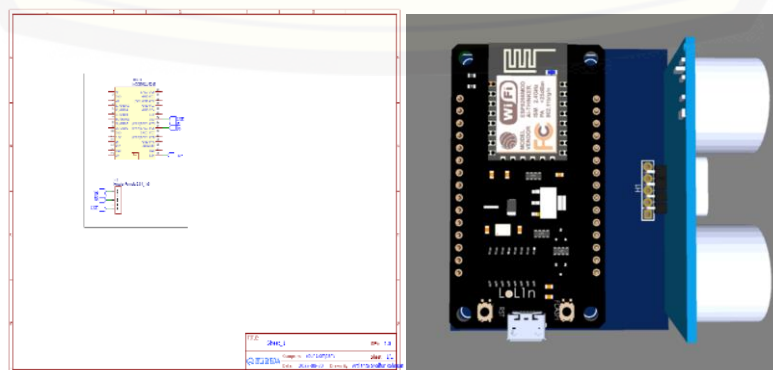

**Figure 6. Shield HYSRF05**

Figure 6 shows the design of the HY-SR 05 is an ultrasonic transmitter/receiver used to measure distances with a precision of ~0.3cm. The HY-SRF05 sends a 40 KHz wave signal that bounces off objects in front of the sensor. This signal is then read back by the sensor and the duration of the received signal is reflected on the ECHO pin. Characteristics Supply voltage: 4.5V to 5.5V (VCC) Use the elapsed time in the following formula to find the distance in cm using this equation in (1).

$$d = v * \frac{t}{2} \quad (1)$$

where

- d is distance.
- v is speed of sound 0.034 cms/us.
- t is total measured time 588 us

The HY SRF05 sensor used during calibration is 1 piece, where the sensor is placed at a distance from the surface of the lid. The error is calculated using equation (2):

$$Error(\%) = 100\% \times \frac{|JS-JA|}{JA} \quad (2)$$

Where, JS is the sensor reading distance, and JA is the actual distance. In this case the actual distance is the distance obtained through manual measurement using a ruler.

#### F. Power Source Characteristic

PLN (Perusahaan Listrik Negara) is electrical energy company in Indonesia using alternating current or alternating current (AC) electricity generated from an AC generator. Voltage and alternating current are usually expressed in terms of RMS (Root Mean Square) values. The RMS itself is usually known as the mean squared whose statistical measurement of magnitude has an arbitrary magnitude. Calculating the change in voltage and current in a sine manner can be calculated by equation (3):

$$V_{rms} = A * \frac{1}{\sqrt{2}} \quad (3)$$

where

- $V_{rms}$  is root mean square Voltage.
- A is the amplitude of the signal being sampled.

Electrical power is the rate of transmission of electrical energy in an electric circuit. Electrical power consists of, active power using equation (4), reactive power using equation (5), and apparent power using equation (6):

$$P = V \times I \times \cos \phi \quad (4)$$

$$Q = V \times I \times \sin \phi \quad (5)$$

$$S = V \times I \quad (6)$$

where

- V is voltage (Volt).
- I is current (Ampere)
- P(Active Power), Q(Reactive Power), S(Apparent Power)
- Cos phi, Sin phi is power factor.

#### G. Software Design Flutter Framework Adoption Scheme

Figure 7 shows the flowchart and user interface application of the flutter schema adoption that uses MQTT data communication which allows dashboard visualization and output control in publish and subscribe sensor data values to application dashboards, Influxdb databases, and Notifications on Mobile Applications by combining API (Application) programs. Programming Interface) NodeJs with Node-Red.

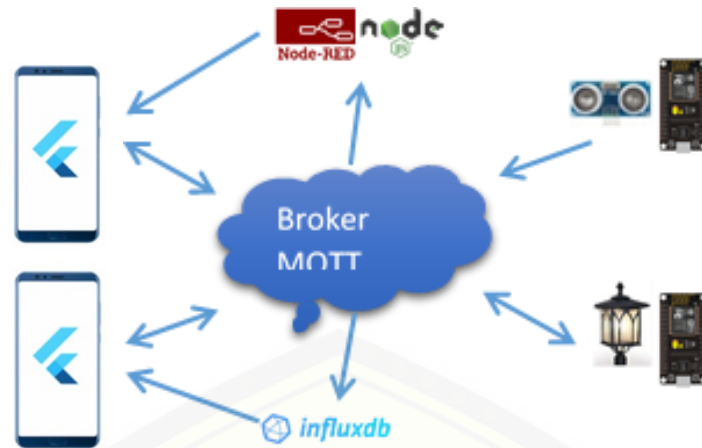

**Figure 7. Flowchart of Mobile Apps using the Flutter Framework Adoption Scheme**

### III. RESULT

#### A. Data Collection from HY-SRF05 on Ground Water Tank

Data retrieval using a scale of 1:100 from the actual situation (water level status of the Ground Water Tank). Data retrieval is done by placing the sensor on the surface of the underground water reservoir cover then the distance of the object from the sensor is reduced according to the maximum limit for underground water storage. The data taken is 20 times sensor readings with a time lag of each reading for 3 seconds.

**Table 1. Average Actual Distance with Ultrasonic Sensor Reading Distance HYSRF05**

Actual Distance (cm)	Sensor Reading Distance (cm)	Relatif Error (%)
50	49,82	0,36
75	74,96	0,05
100	99,87	0,17
125	125,12	0,09
150	149,91	0,05

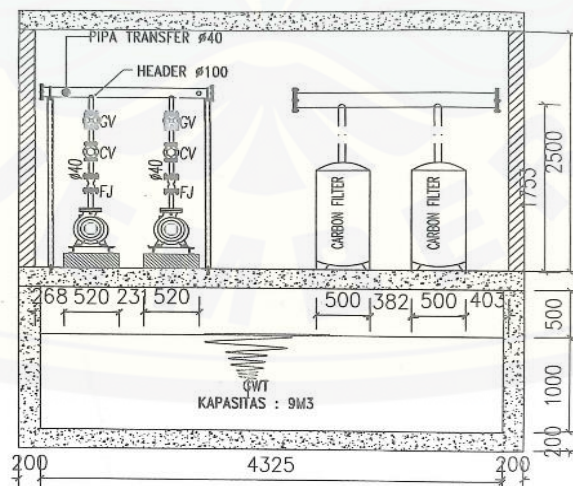

**Figure 8. Dimensions of GWT (Ground Water Tank)**

#### B. Waterlevel Monitoring Dashboard

Regulate the availability of water in the ground water tank reservoir for monitoring water in the ground water tank with a smartphone connected to the internet with the MQTT protocol. With the monitoring dashboard on the Mobile application programmed using the flutter framework, it allows users to manage and optimize water level equipment and control water pump using IoT (Internet of things) especially using the MQTT protocol.

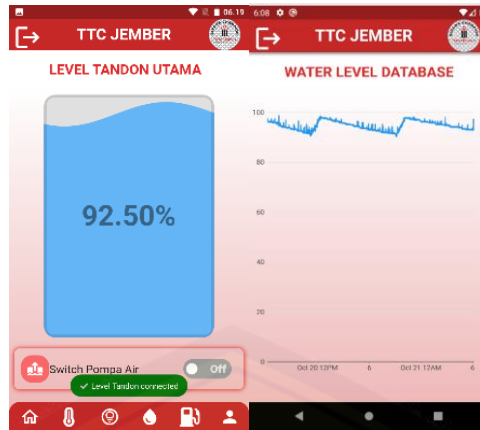

**Figure 9. Visualization of Flutter Interface Application with MQTT Waterlevel Monitoring Dashboard on Mobile Apps**

Figure 9 shows the design of the Mobile dashboard application for visualization of the reservoir water level using the flutter framework which is connected to the mqtt and influxdb databases and is integrated with notifications programmed through Node red and the Nodejs API.

**C. Lighting Control Dashboard**

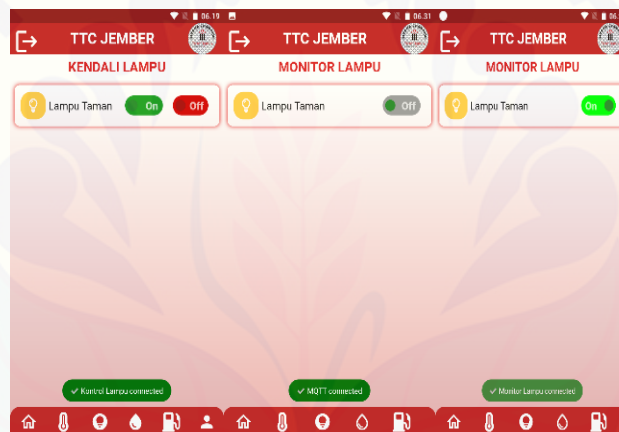

**Figure 10. Visualization of the Lighting Control Interface Flutter Application with MQTT**

Figure 10 shows the implementation of the lighting control dashboard mobile app and conducted experiments to test the reliability of the system and to estimate response times from both the app and web accounts. The results showed that the lamp control system was reliable and more convenient, in controlling the switching operation of the Mobile application designed and programmed with the flutter framework, the system only needed a few seconds to control the operation.

**D. Direct Notify from Apps**

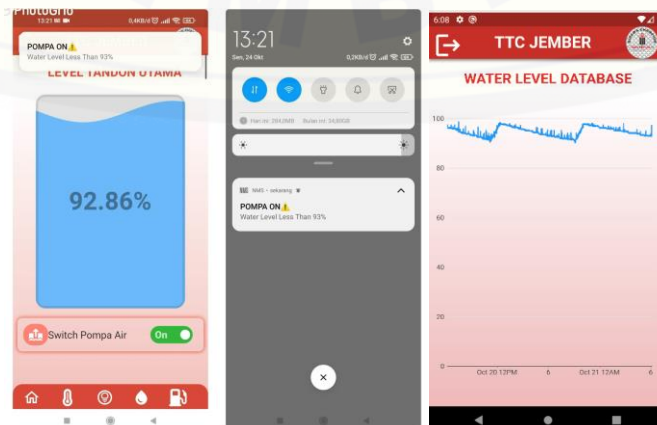

**Figure 11. Visualization of the Application Notification interface with the Flutter Framework**

We simulate notifications with the upper and lower limits of the water level. In our setting the water level is less than 93%, we mark it as a water shortage condition. For water levels above 98%, we mark it as full. Figure 11 is a graph on the dashboard showing when the water level is less than 93%. It detects that the water level is less than 93% at 1:21 pm and automatically turns the water pump on. And Figure 10. shows that the water level is over 98% at 2:31 p.m. and automatically turns the water pump off.

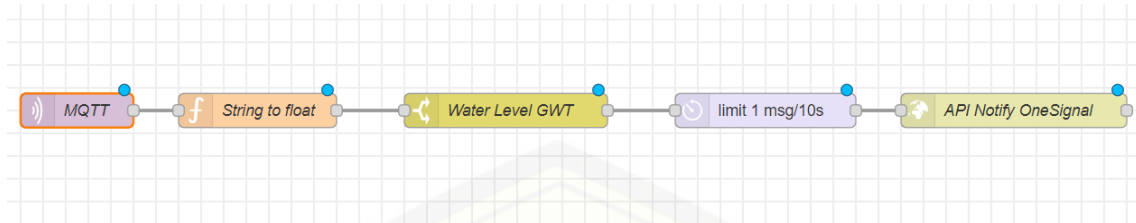

**Figure 12. Node Red Flow Visualization for Sending Notifications on Mobile Apps with NodeJs API**

Figure 12 Node-red is an MQTT client that subscribes to MQTT Broker on topics published by the device. Researchers designed a flow to manage and manage data from device sensors, the http request node (API Notify OneSignal) is a node that connects to the notification service on Mobile apps via the web API. Thus, users who are registered with Mobile Apps, Node-Red Notification service and NodeJs API will send notification messages to users at 13:21 and notification messages at 14:31 as shown in Figure 11.

**E. Database InfluxDB**

The outermost construct of InfluxDB is called organization, which is a dashboard consisting of buckets, which are named locations where all time series data is stored. All buckets have a time duration, called a retention period, during which each data point remains, and when a point has a timestamp that is longer than the retention period, it is deleted by InfluxDB to reduce overall disk usage. Measures are conceptually similar to tables in a relational database, and are named buckets for tags, fields, and timestamps.



**Figure 13. InfluxDB Database**

Figure 13 shows a bucket and dashboard named “Water Level Ground Water Tank”, which contains monitoring measurements for the height of the stored underground water reservoir (GWT).

**F. Power Consumption**

**Table 2. Data Load Panel Device**

Panel	LOAD (Ampere)			Average (Ampere)
	R	S	T	
Lighting	3,4	3,8	0,6	4,2 A
Water Pump	0	0	4,9	

Based on the amount of load on each device, we get a calculation of the power consumption of each device by comparing power consumption based on the use of water pump and lighting equipment loads before and after the design of the Internet of Things-based Lighting and Watering Automation System. With the PLN line to line voltage input 380V and line to neutral input 230V with  $\cos \phi = 0,972$  the power consumption per day is obtained through equation (4):



**Table 3. Power Consumption Data Based on Load Usage**

Load Type	Daily Usage		Power (kWh)	
	Before	After	Before	After
<b>Lighting</b>	<b>11 hour</b>	<b>10 hour</b>	<b>19,2</b>	<b>17,4</b>
<b>Water Pump</b>	<b>6 hour</b>	<b>4 hour</b>	<b>6,6</b>	<b>4,4</b>
Load Type	Monthly Power Usage (kWh)			
	August 2022		September 2022	
<b>Lighting</b>	<b>575,44</b>		<b>523,13</b>	
<b>Water Pump</b>	<b>197,17</b>		<b>131,45</b>	

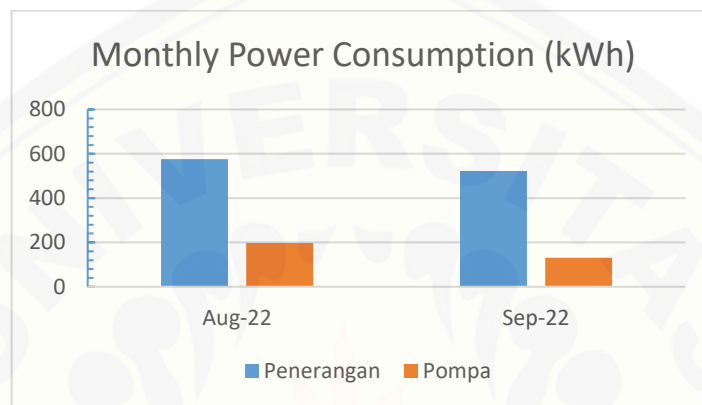

**Figure 14. Monthly Power Consumption Chart**

The power consumption of lighting and water pump loads in Figure 14 shows the power consumption before and after the design of this system which is compared and calculated in the period from August 2022 to September 2022 has an impact on power savings of 118.03 kWh.

#### IV. CONCLUSION

We present low-cost lighting and watering automation system design. The design of Lighting and Watering automation system with Message Queuing Telemetry Transport Protocol and Flutter Framework was created using a NodeMCU ESP8266 board device connected to a HYSRF05 sensor to detect the water level of underground reservoirs and a Switching Driver to control Lighting and Water Pump for irrigating underground water reservoir. In the calibration carried out for the ultrasonic sensor, it can be concluded that the sensor works well from a distance of 50 cm to 150 cm with a maximum relative error of 0.36% with a minimum change detected by the sensor of 0.04 cm with a maximum relative error of 0.05%. Power consumption on lighting and water pump loads after the system design has an impact on power savings of 118.03 kWh. Lighting control and underground water tank automation are implemented in the Mobile application using the Flutter framework to receive and display lighting control data with large power loads and underground water level monitoring data or GWT (Ground Water Tank). With the Flutter framework, we designed the flow to manage and handle water level monitoring system data in underground reservoirs or (Ground Water Tank) and garden lighting control, so that users can set conditions to notify users about water level thresholds through the Mobile Notify service which integrated in real-time via Node-RED, NodeJS API, and devices communicating via MQTT Broker in a publish and subscribe model.

#### REFERENCES

- [1] Mtshali, Progress, and Freedom Khubisa. "A smart home appliance control system for physically disabled people." 2019 Conference on Information Communications Technology and Society (ICTAS). IEEE, 2019.
- [2] Waleed, Jumana, Areej M. Abduldaim, Taha Mohammed Hasan, and Qutaiba Salih Mohaisin. "Smart home as a new trend, a simplicity led to revolution." In 2018 1st International Scientific Conference of Engineering Sciences-3rd Scientific Conference of Engineering Science (ISCES), pp. 30-33. IEEE, 2018.
- [3] P.Machesoae, T.D.Mandab, S.Chisalec, N.Dzupired, J.Mlathoa and D.Mukanyiligirae "Design of ESP8266 Smart Home Using MQTT and Node-RED" International Conference on Artificial Intelligence and Smart Systems (ICAIS-2021). IEEE; 2021.

- [4] Emmanuel I. Nwankwo, Elizabeth N. Onwuka, Michael David and Zubair Suleiman. "Hybrid MQTT-COAP Protocol for Data Communication in Internet of Things" Institutional Based Research Intervention (IBRI). IEEE; 2021.
- [5] A. Rizzardi, S. Sicari, D. Miorandi, and A. Coen-Porisini, "AUPS: An Open Source AUthenticated Publish/Subscribe system for the Internet of Things," *Inf. Syst.*, vol. 62, pp. 29–41, 2016.
- [6] R. A. Light, "Mosquito : server and client implementation of the MQTT protocol," no. May, pp. 10–11, 2017.
- [7] Paul Macheso, Tiwonge D. Manda, Sylvester Chisalec, Nelson Dzuired , Justice Mlatho and Didacienne Mukanyiligira. " Design of ESP8266 Smart Home Using MQTT and Node-RED" IEEE Proceedings of the International Conference on Artificial Intelligence and Smart Systems (ICAIS), 2021.
- [8] Mohammed Abduljabbar Hayil Hayil, "Home Automation System And Methods(Control System in Lighting and Devices) in Fuel Supply Station," in IEEE Explore Auckland University of Technology , 2020.
- [9] K.Jaikumar, T.Brinda, T.K Deepalakshmi, S. Gomathi , "IOT Assisted MQTT for Segregation and Monitoring of Waste for Smart Cities ," in IEEE 6th International Conference on Advanced Computing & Communication Systems (ICACCS), 2020.

