

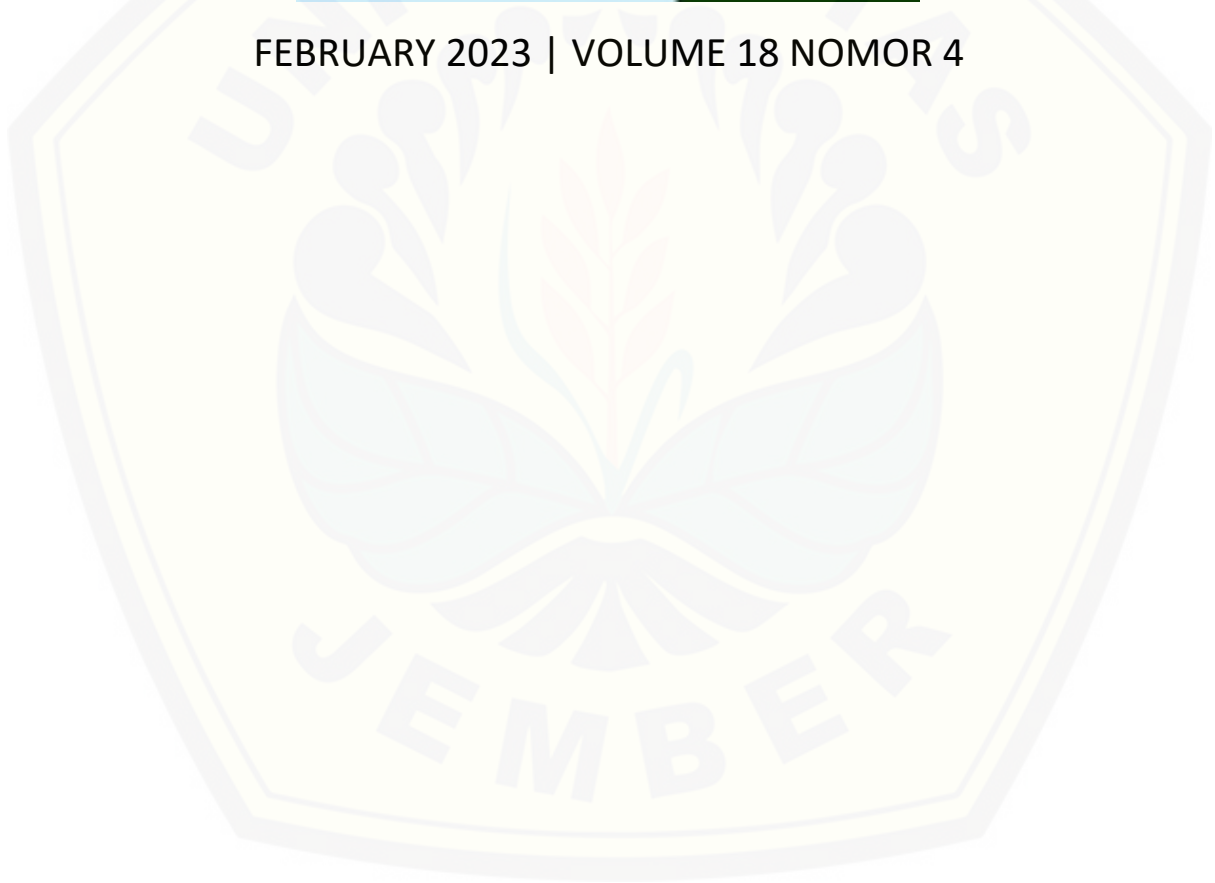

FEBRUARY 2023 | VOLUME 18 NOMOR 4



February 2023 | Vol. 18 No. 4

Table of Contents

Accepted Refereed Research Articles

Design and simulation of a user-friendly solar operated grass cutting device <i>Nader Ghareeb</i>	ABSTRACT PDF 257-263
Design study of 300MWth GFR with UN-PuN fuel using SRAC-COREBN code <i>Ratna Dewi Syarifah, Mila Hidayatul Aula, Artoto Arkundato, Agung Tjahjo Nugroho, Gaguk Jatisukanto and Septy Handayani</i>	ABSTRACT PDF 264-270
Effect of soil friction on performance of hybrid mechanically stabilized earth walls with large spacing <i>Abdullah F. Alluhaybi</i>	ABSTRACT PDF 271-279
Magnetic and optical properties of cobalt-doped hematite nanoparticles of logas natural sand for environmental application <i>Erwin Amiruddin, Salomo Sinuraya, Amir Awaluddin, Rahmondia Nanda Setiadi, Muhammad Rizki, Novalia Magdalena Purba and Indah Tamara Sitorus</i>	ABSTRACT PDF 280-285
Numerical study of aggregate effects on the strength of light concrete <i>Miryuk O. A., Oleinik A. I. and Akhmedov K. M.</i>	ABSTRACT PDF 286-294
Towards a detailed urban structural mapping using outcrop, geophysical and borehole data integration: Implications for sustainable development <i>Ahmed Henaish, Mohamed Attwa, Mohamed Elnahal and Kareem Mohsen</i>	ABSTRACT PDF 295-310
Improved median filter to eliminate salt and pepper noise in digital <i>Adnan Manasreh, Mohammad S. Khrisat, Hatim Ghazi Zaini, Ziad A. Alqadi and Nasser Abdellatif</i>	ABSTRACT PDF 311-316
Correlation analysis of preliminary breakdown and first return stroke process in negative ground flash as a function of Northeast and Southwest monsoon in tropic <i>Nur Asyiqin Isa, Zikri Abadi Baharudin, Hidayat Zaimuddin, Ts. Zaihasraf Bin Zakaria, Ts. Ahmad Idil Bin Abdul Rahman, Ahmad Aizan Bin Zulkefle, Maslan Bin Zainon and Mohd. Ariff Bin Mat Hanafiah</i>	ABSTRACT PDF 317-326
Maxwell-Nanofluid flow, heat and mass transfer past a stretching sheet with multiple slip, heat source and chemical reaction effects using FEM <i>Khaja Hassan, R. Vijaya Kumar and G. Srinivas</i>	ABSTRACT PDF 327-344
Evaluation of brain tumor classification techniques on identification of EEG in medical images <i>Swathi dasi, T. Mahalakshmi, K. Srinivasa Rao and Rama Krishna Merugumalli</i>	ABSTRACT PDF 345-351
Color obstacle detection algorithm using AR drone 2.0 in a controlled environment <i>Faiber Robayo Betancourt and Daniel Suescún-Díaz</i>	ABSTRACT PDF 352-357
Multi-Scale Region-Of-Interest based Deep Learning for fruit disease identification and classification <i>Kavitha S. and Sarojini K.</i>	ABSTRACT PDF 358-368
The simple way to build a geoelectrical instrument <i>Risky Martin Antosia</i>	ABSTRACT PDF 369-380
Using a Gesture Recognition Modeling approach to improve graphical user interface <i>Issam El magrouni, Abdelaziz Ettaoufik, Aouad Siham, Aberrahim Maizate and Bennani Lotfi</i>	ABSTRACT PDF 381-392

Editorial Board

Editor-in-Chief: Engr. J. K. Tarakzai (PAKISTAN)

#	Editors	Country
1	Prof. Dr. R. J. Godwin	UNITED KINGDOM
2	Prof. Dr. Erik Valdemar Cuevas Jimenez	GERMANY
3	Dr. Iftikhar Ahmad	SAUDI ARABIA
4	Prof. Dr. Hamou SADAT	FRANCE
5	Dr. Mohammad Aminul Islam	JAPAN
6	Prof. Dr. Kui Fu Chen	CHINA
7	Dr. Muhammad Imran	AUSTRALIA
8	Prof. Dr. M. Ashraf Chaudhry	NEW ZEALAND
9	Prof. Dr. A. Sermet Anagun	TURKEY
10	Prof. Dr. Ashraf Mohamed Hemeida	SAUDI ARABIA
11	Prof. Dr. Krishna Murari Pandey	INDIA
12	Prof. Dr. Magdy A. Ezzat	EGYPT
13	Prof. Dr. Roberto Brighenti	ITALY
14	Dr. Anurag Misra	INDIA
15	Prof. Dr. Adel M. ALIMI	TUNISIA
16	Prof. Dr. Arun Kumar Gupta	INDIA

17	Prof. Demetrios V. Bandekas	GREECE
18	Prof. Dr. Bensafi Abd-El-Hamid	ALGERIA
19	Dr. Rajanish K. Kamat	INDIA
20	Prof. Dr. Asma Thamir Ibraheem	IRAQ
21	Prof. Dr. Sylejman Hyseni	KOSOVO
22	Prof. Dr. Haider Zaman	SAUDI ARABIA
23	Prof. Dr. Debojyoti Mitra	INDIA
24	Prof. Dr. Pandian VASANT	MALAYSIA
25	Prof. Dr. Prakash MMS Kinthada	INDIA
Associate Editors		
1	Dr. Dongning Li	USA
2	Dr. Suheyla Yerel	TURKEY
3	Dr. Guoxiang Liu	USA
4	Dr. Nadeem Anjum	PAKISTAN
5	Engr. Malini Sarah Philip	NORWAY
6	Dr. K.V.L.N. Acharyulu	INDIA
7	Engr. Mohammad Khalily Dermany	IRAN
8	Dr. Lamyaa- Gamal Eldeen Taha	EGYPT



DESIGN STUDY OF 300MWTH GFR WITH UN-PuN FUEL USING SRAC-COREBN CODE

Ratna Dewi Syarifah¹, Mila Hidayatul Aula¹, Artoto Arkundato¹, Agung Tjahjo Nugroho¹, Gaguk Jatisukanto² and Septy Handayani³

¹Department of Physics, Faculty of Mathematics and Natural Sciences, Universitas Jember, Indonesia

²Department of Mechanical Engineering, Faculty of Engineering, Universitas Jember, Indonesia

³Department of Nutrition, Faculty of Public Health, Universitas Jember, Indonesia

E-Mail: rdsyarifah.fmipa@unej.ac.id

ABSTRACT

Research related to 300MWth with UN-PuN fuel optimization on GFR using 3D core (X-Y-Z) with the code SRAC-COREBN has been carried out. UN-PuN fuel optimization was carried out by studying neutronic parameter analysis on variations in the addition of Pu-239 percentages in homogeneous and heterogeneous core configurations, as well as on variations in fuel volume fractions. The design of the reactor core is cylindrical pancake with a diameter of 300 cm and a height of 100 cm. Neutronic calculations are carried out in two steps, the first is the calculation of burn-up per fuel pin using the PIJ code system on SRAC and the JENDL4.0 nuclide library. The second calculation is the calculation of burn-up at the reactor core level using the COREBN code. The results of the core burn-up calculation analyzed were neutronic parameters, such as k-eff, excess reactivity, and power density. The optimal design based on the neutronic parameter analysis that has been carried out is a fuel volume fraction of 64% with a heterogeneous core configuration of 3 types of fuel percentage, fuel 1- fuel 2- fuel 3 = 7.5%-8%-8.5%. The maximum k-eff value is 1.0031841 with a maximum excess reactivity of 0.32%. The maximum power density for the X and Y directions is 70.78 Watt/cc; while for the Z direction it is 67.97 Watt/cc.

Keywords: SRAC-COREBN, GFR, UN-PuN.

INTRODUCTION

According to GIF, there are six proposed generation IV reactor designs for fulfill the world's future energy demand, one of which is the Gas Cooled Fast Reactor (GFR) system. The GFR system is a helium gas-cooled fast reactor with a closed fuel cycle. With a combination of fast neutron spectra and actinide recycling, GFR can minimize the production of long-lived radioactive waste isotopes by breeding plutonium. The core outlet temperature reaches 800 to 850 °C, which is the advantage of GFR technology. At this temperature, the GFR is suitable for hydrogen production (GIF, 2002). Based on several things that have been mentioned, GFR was chosen as one of the Generation IV nuclear reactor systems developed based on its excellent sustainability potential. However, GFR has challenges in terms of fuel resistance and efficient fuel cycle processes in its development (Anggoro *et al.*, 2013).

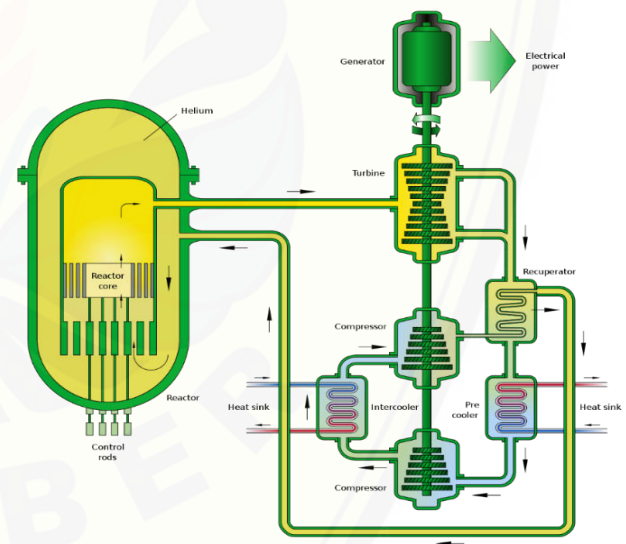

Figure-1. GFR scheme (GIF, 2002).

The design of the reactor core design is the initial stage and one of the important parts in the development of the GFR in order to produce a reactor with a fuel cycle that has high resistance and is efficient in a predetermined operating time (GIF, 2020). Therefore, it requires the development of the GFR core design, one of which is by optimizing fuel. To achieve optimal fuel, careful analysis is required, one of which is by neutronic analysis.

LITERATURE REVIEW

Research related to neutronic analysis for GFR has been widely carried out. Research (Syarifah *et al.*,



2016), indicating that the gas-cooled fast reactor with UN-PuN fuel has reached optimum with a burn-up period of 10 years without refueling. Neutronics analysis performed using SRAC code with JENDL-3.2 as nuclides data library. Study design of modular fast reactor with helium gas cooling (GFR) that can be operated for 20 years has been carried out (Ilham and Su'ud, 2017). The research calculated neutronic analysis of GFR with Mixed Oxide fuel (UO₂-PuO₂) using the code SRAC-CITATION. The result obtained is the effective multiplication factor and the value of the power density of the reactor core. Other research (Syarifah *et al.*, 2017) states that the UN-PuN-fueled 500 MWth GFR reaches optimum with a burn-up period of 25 years. Neutronic analysis is performed with the CODE FI-ITB-CHI code. Further research (Syarifah *et al.*, 2020) analyzed the effect of the addition of minor actinides on the k-eff value in gas-cooled fast reactor fuels. The addition of minor actinides in the form of americium (Am-241 and Am-243) and neptunium-237 to the uranium plutonium nitride material succeeded in reducing the k-eff value. The other research about neutronic analysis on small modular gas-cooled fast reactors using the Open MC code has been carried out (Ilham, Rafli and Suud, 2020). The neutronic parameter analyzed in this study is the effective multiplication factor (k-eff), neutron flux, and power.

Design studies of GFR 800 MWth, 900 MWth, and 1000 MWth fueled by uranium plutonium nitride with a CANDLE burn-up scheme have been carried out (Syahputra, Razak and Su'ud, 2020). This study was conducted using a two-dimensional R-Z cylindrical cell model with the code SRAC-CITATION. Research (Irka *et al.*, 2021) investigated the neutronic performance of natural uranium-fueled GNRs by using a modified CANDLE combustion scheme in the radial direction with a reactor output power varying from 300-600 MWt. Research (Syarifah *et al.*, 2021), is an early study of the use of uranium carbide fuel in gas-cooled fast reactors. The use of uranium carbide fuel shows less than optimal results when compared to the use of UN-PuN.

Based on the studies that have been carried out related to neutronic analysis in GFR, this study is aimed at determining the results of optimization of uranium-plutonium nitride (UN-PuN) fuel in gas-cooled fast reactors analyzed in terms of neutronics using a 3D core with the code SRAC-COREBN. The objectives of the study were achieved by analyzing neutronic parameters on the addition of plutonium percentages in homogeneous and heterogeneous core configurations, and variations in fuel volume fractions using the SRAC-COREBN code. The neutronic parameters analyzed include the multiplication factor (k-eff), excess reactivity, and power density during the reactor operation period.

METHOD

The reactor used in the study was a 300MWth power GFR type with specifications shown by Table-1.

Table-1. Reactor specifications.

Parameter	Specifications
Power	300 MWth
Core Geometry	Pancake Cylinder
Active core height	100 cm
Active core diameter	300 cm
Burn-up period	10 years
Fuel Material	Uranium-Plutonium Nitrida (UN-Pun)
Fuel pin Geometry	Hexagonal
Cladding material	Silicon carbide
Coolant material	Helium
Density of fuel (gr/cm ³)	14.32
Variation of Plutonium Percentage (%)	6-15
Variation of Fuel Volume Fraction (%)	60-65
Variation of Cladding volume fraction (%)	10
Variation of Coolant Volume Fraction (%)	25-30
Pin pitch (cm)	1.45

The fuel pin used is in the form of a hexagonal pin divided into six regions, as shown in Figure-2. The three most central regions are fuel, the next one region is cladding, and the last two regions are coolant.



Figure-2. Fuel pin.

The reactor core design uses the pancake cylinder type shown in Figure-3. The design configuration of the reactor core in this study used two types, namely homogeneous and heterogeneous. Homogeneous core configurations use the same percentage of fuel, while heterogeneous core configurations use several types of fuel percentages.

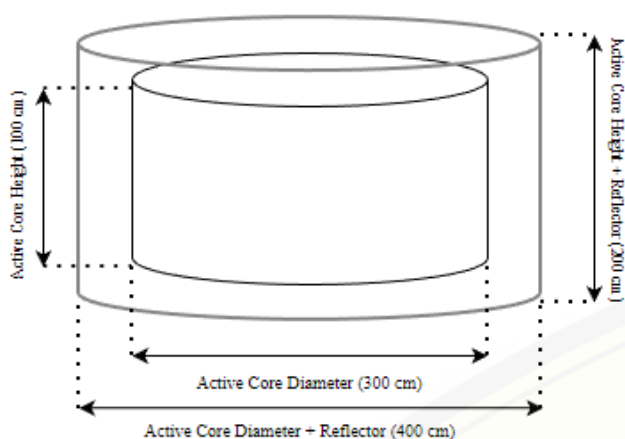

Figure-3. Reactor core geometry.

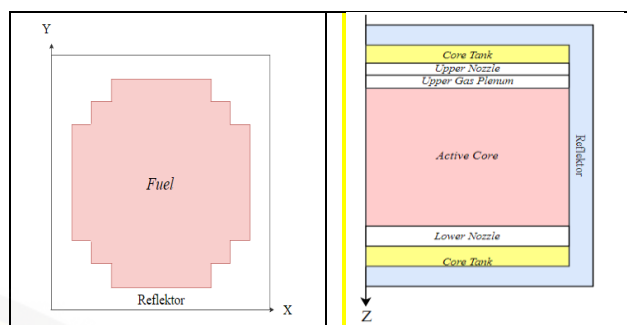

Figure-4. 3D burn-up calculation model (Okumura, 2007).

Neutronics calculations using the SRAC-COREBN code are divided into two stages, the first is the calculation of burn-up at the fuel cell level (fuelpin) using the PIJ code system on SRAC and the JENDL4.0 nuclide library. SRAC (Standard Reactor Analysis Code) is a code system for neutronic analysis for various types of reactors developed by JAEA (Okumura *et al.*, 2002). The SRAC code uses the diffusion equation approach. The neutron diffusion equation is a balance equation that describes neutron transport in space, energy, and time. The solution of the diffusion equation contains a neutron flux that represents the rate of neutrons in interacting with the surrounding medium as well as neutrons leaking out of the reactor (Suparlina *et al.*, 2010). The diffusion equation of multigroup neutrons can be mathematically written as follows.

$$-\vec{\nabla} \cdot D_g \vec{\nabla} \phi_g + \Sigma R_g \phi_g = \frac{\lambda_g}{k_{eff}} \sum_{g^1}^{g^n} v_{g^1} \Sigma f_{g^1} \phi_{g^1} - \sum_{g^1}^{g^n} \Sigma_{sg} \rightarrow g^i \phi_{g^i}$$

(Duderstadt, 1976)

The second calculation is the calculation of burn-up at the reactor core level using the COREBN code with a 3-dimensional core burn up calculation model (X-Y-Z), shown by Figure-4. COREBN is a code that multi-dimensional core burn-up calculations use based on the theory of diffusion and interpolation of macroscopic cross-sections that are tabulated to local parameters such as burn-up degree, moderator temperature, and so on (Okumura, 2007).

The calculation using COREBN code begins with preparing a PDS to PS code for macro file conversion. The result of the cell-level burn-up calculation is in the form of a PDS format MACRO file so that to convert PDS file to PS, PDS to PS code is required. Then initiation of the calculation of the HIST code as a history file. The calculation scheme of SRAC-COREBN can be seen in Figure-5. The output produced in the core calculation is the value of k-eff, excess reactivity, and power density.

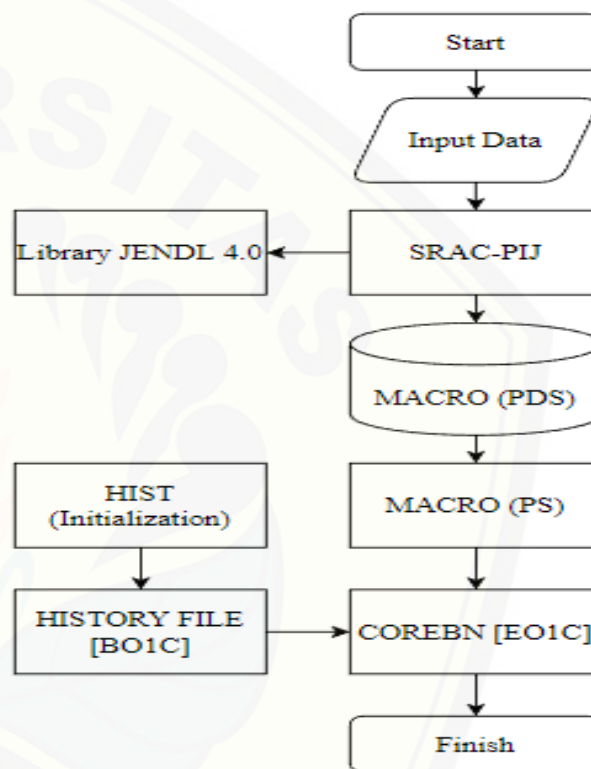

Figure-5. SRAC-COREBN Calculation Scheme.

The analysis carried out included: analysis of neutronic parameters for each percentage variation of Plutonium-239 in UN-PuN fuel in homogeneous and heterogeneous core configurations, as well as analysis of neutronic parameters for variations in fuel volume fractions. Neutronic parameter analysis for UN-PuN fuel optimization results is seen from the condition of the k-eff value of one (critical condition) the maximum excess reactivity value is close to zero, as well as distribution of power in the reactor.

RESULT AND DISCUSSIONS

Research on the optimization of uranium plutonium nitride (UN-PuN) fuel in gas-cooled fast reactors has been carried out. First, an analysis of the effect of adding percentages of Pu-239 in UN-PuN fuel on homogeneous configurations on neutronic parameters. A homogeneous core is a configuration with the same percentage value of fuel (fuel 1 = fuel 2 = fuel 3). The



addition of the percentage of Plutonium-239 is carried out from a percentage of 6% to 15%.

Figure-6 shows the k-eff value to the burn-up period in a homogeneous core configuration. In the picture, the value of k-eff is increasing along with the increase in the percentage of fuel. A large percentage of fuel has a lot of fissile fuel so that the neutron activity in the reactor also increases. The 8% Plutonium-239 percentage has the most stable k-eff value close to one after its burn-up period.

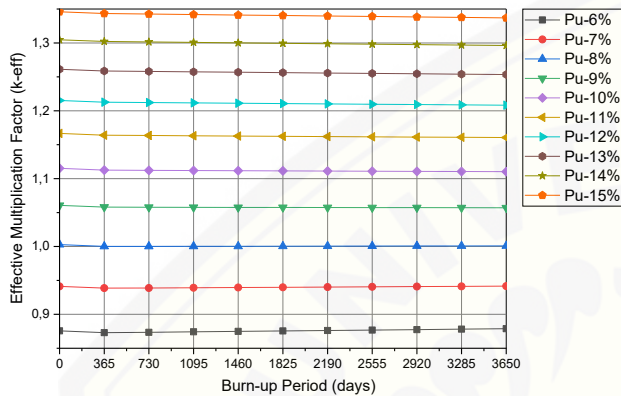

Figure-6. Graph of k-eff for each addition of Plutonium-239 on homogeneous core.

The second neutronic parameter analysis is the value of excess reactivity. The value of excess reactivity (ρ) or excess reactivity is the value of the change in the effective multiplication factor of the reactor core caused by the condition of the reactor. The value of excess reactivity is constantly changing due to changes in the operating conditions of the reactor along with the addition of the percentage of Plutonium-239, shown in Table-2. The best excess reactivity value is the one closest to zero because it indicates that the reactivity in the reactor is stable. The Plutonium-239 percentage of 8% has a maximum excess reactivity value of 0.28%.

The next analysis is the analysis of the power density. The average power density value limit is 70 Watts/cc, and the maximum power density value is 100 Watt/cc to create a GFR that operates over a long period of time. Table-2 shows the average value of the power density at each addition of plutonium-239 percentages. Based on the table, it shows that the more the percentage of Plutonium-239, the higher the power density value. The average power density value at a plutonium percentage of 8% is 75.03 Watt/cc with its maximum power density value being 107.4 Watts/cc.

Table-2. Power density on homogeneous core.

Percentage Plutonium -239 (%)	Average power density (Watts/cc)	Maximum Power density (Watts/cc)	Excess Reactivity max (%)
6	73.77	104.71	-14.21
7	74.45	106.17	-6.25
8	75.03	107.4	0.28
9	75.52	108.46	5.72
10	75.95	109.37	10.33
11	76.79	110.07	14.29
12	76.57	110.68	17.71
13	76.81	111.18	20.71
14	77.01	111.57	23.35
15	77.16	111.87	25.70

The second study was the analysis of neutronic parameters on heterogeneous core configurations. The addition of the Percentage of Plutonium-239 to UN-PuN fuel with heterogeneous core configurations is carried out by varying the percentage of fuel 1 and fuel 3, while fuel 2 will be of fixed value as a reference percentage. The reference percentage is taken from the most optimal percentage value in a homogeneous configuration. The percentage variation of Plutonium-239 for heterogeneous core is shown by Table-3.

Table-3. Plutonium-239 percentage variation in heterogeneous configurations.

Case-	Plutonium-239 Percentage (%)		
	fuel 1	fuel 2	fuel 3
1	5.5	8	10.5
2	6	8	10
3	6.5	8	9.5
4	7	8	9
5	7.5	8	8.5

Figure-7 shows the relationship of k-eff values to burn-up time in heterogeneous core configurations. All cases show a k-eff value below one. This is called a subcritical condition; the condition of the neutron population goes down with each generation. The closest k-eff value to one is Case 5 with a percentage of 7.5%-8%-8.5% with a maximum k-eff value of 0.9911901.

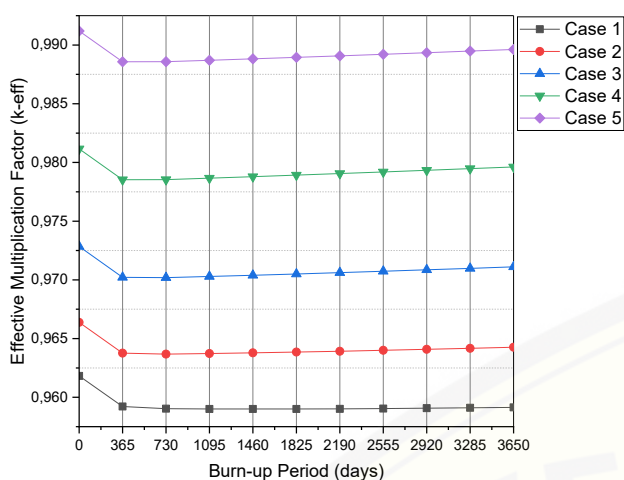

Figure-7. Graph of k-eff for each addition of Plutonium-239 on heterogeneous core.

The next analysis is the value of excess reactivity. Case 5 with a percentage of fuel 1- fuel 2- fuel 3 is 7.5%-8%-8.5% has an excess reactivity value of -0.88%. A negative value indicates that the power in the reactor is in a subcritical state. The reactivity of the core decreases due to changes in the condition of the core configuration arrangement so that it affects the entry of neutron sources or neutron absorbers into the core and affects the fission reaction that occurs. Based on Table-4, Case 5 (7.5%-8%-8.5%) has an average power density of 69.75 Watts/cc and a maximum power density of 95.14 Watts/cc.

Table-4. Power density on heterogeneous core.

Case-	Average power density (Watts/cc)	Maximum Power density (Watts/cc)	Excess Reactivity max (%)
1	76.23	110.18	-3.97
2	72.47	101.8	-3.47
3	68.9	95.38	-2.79
4	68.29	95.18	-1.92
5	69.75	95.14	-0.88

The third study was the analysis of neutronic parameters on variations in the volume fraction of fuel. The variation in the fraction of the volume of fuel begins at fractions from 60% to 65% with an increase per one percent. The percentage used in the fuel volume fraction analysis study was in the heterogeneous configuration of Case 5 with the percentage of plutonium in fuel 1- fuel 2- fuel 3 = 7.5%-8%-8.5%. A graph of the relationship of k-eff with the burn-up period at variations in the fuel volume fraction is shown by Figure-8. On the chart it is seen that the increase in the fraction of fuel volume is proportional to the increase in the value of k-eff. The most optimal k-eff value is obtained when the volume fraction of fuel is 64%. Graph of the k-eff value on the fraction of fuel volume closest to the value of one along its burn-up

erythode. It is this condition that signals that the fission reaction in the reactor is most stable.

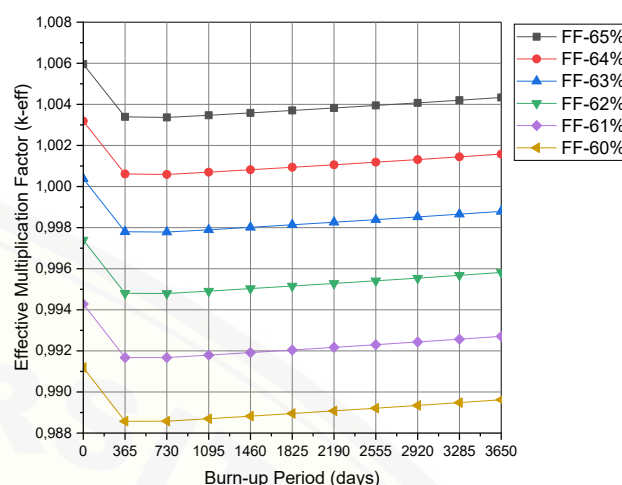

Figure-8. Graph of k-eff on fuel volume fraction variations.

The next analysis is the analysis of the value of excess reactivity. Table-5 shows that the value of excess reactivity is proportional to the increase in the fraction of fuel volume. The fuel volume fraction of 64% obtains a maximum excess reactivity value of 0.32%. Based on table 5, the average power density value at a fuel volume fraction of 64% is 70.78 Watt/cc with a maximum power density of 97.98 Watts/cc.

Table-5. Power density on fuel volume fraction variations.

Fuel Volume Fraction (%)	Average power density (Watts/cc)	Maximum Power density (Watts/cc)	Excess Reactivity max (%)
60	69.75	95.14	-0.88%
61	69.66	95.67	-0.57%
62	69.93	96.19	-0.26%
63	70.19	96.71	-0.22%
64	70.78	97.98	0.32%
65	71	98.41	0.59%

Based on the results of the neutronic parameter analysis that has been carried out, the most optimal fuel is in the case 5 heterogeneous configuration with the percentage of plutonium in 1-fuel 2-fuel 3 = 7.5%-8%-8.5% at a fuel volume fraction of 64%. Figure-9 shows a graph of the k-eff value in the optimization results. The maximum k-eff value obtained is 1.0031841 with a maximum excess reactivity of 0.32%.

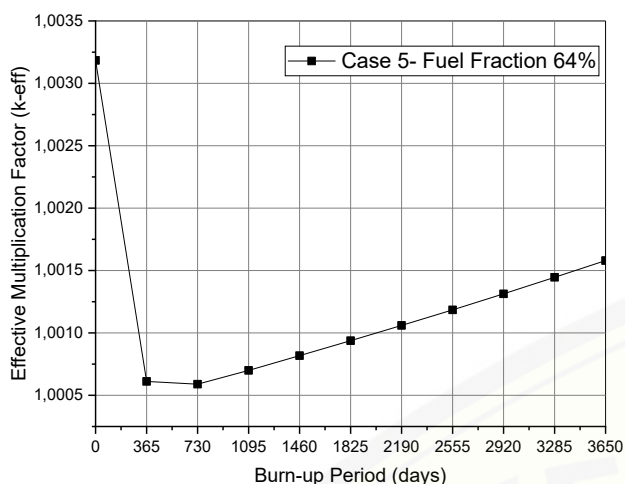

Figure-9. The graph of the k-eff value of the optimization results.

The power density is analyzed for each of its radial and axial directions. Figure-10 is the result of direction X relative power density for optimized results. Direction X is the cross section of the reactor from the left side of the reactor to the right. The per-mesh on the graph represents 5.45 cm of the length of the reactor. The power density is relative in the X direction for the mesh $0 < X < 10$ dan $45 < X < 55$ is colored blue. This is because the area is reflector (non-fuel area) so that a chain fission reaction does not occur in the area and the power density is zero.

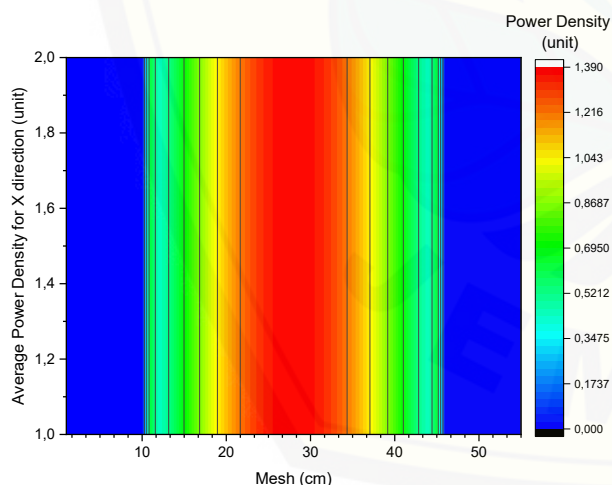

Figure-10. Power density distribution for direction X direction.

Direction Y is the cross section of the reactor from front to back. The blue color for the mesh $0 < X < 10$ dan $45 < X < 55$ its power density value is zero, which indicates the reflector area. The maximum power density for the Y direction is 70.78 Watt/cc with a peak power factor of 1.389232.

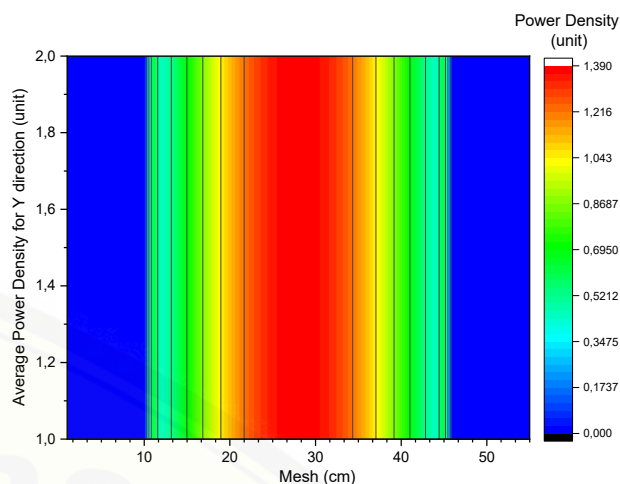

Figure-11. Power density distribution for direction Y.

Figure-12 shows the power density relative to the Z direction by the number of mesh 50. Each mesh represents 2 cm of reactor height. Direction Z is the upper part of the reactor to the bottom of the reactor consisting of the reflector section, upper nozzle, upper gas plenum, fuel arrangement, and lower nozzle. The average power density in the Z direction is 67.97 Watt/cc with a peak power factor of 1.44653. The power density is in the mesh area mesh $0 < Z < 10$ and $40 < Z < 50$ is blue because the area is a non-fuel area so that no fission reaction occurs.

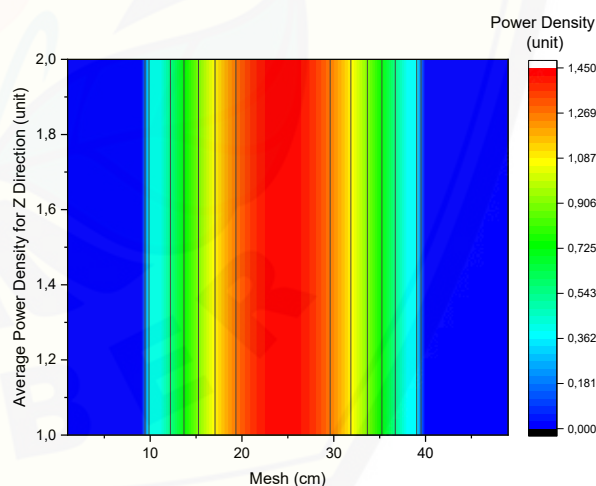

Figure-12. Power density distribution for direction Z.

CONCLUSIONS

Research related to UN-PuN fuel optimization in gas-cooled fast reactors uses the COREBN code. The most optimal neutronic parameter analysis was obtained in the case 5 heterogeneous configuration with the percentage of plutonium-239 in 1-fuel 2-fuel 3 fuel is 7.5%-8%-8.5% with the volume fraction of fuel used is 64%. The maximum k-eff value obtained was 1.0031841 with an excess reactivity of 0.32%. The maximum power density is 97.98 Watts/cc. The average power density of each radial direction obtained is 70.78 Watt/cc.



ACKNOWLEDGMENT

This research was funded by Universitas Jember, Indonesia, for research activities and publication supports. The authors were thanks to LP2M Universitas Jember for funding the research by HibahKelompokRiset dan PengabdianKepada Masyarakat (KeRisDiMas) 2022.

REFERENCES

Anggoro Y. D. *et al.* 2013. Kajian Perkembangan PLTN Generasi IV. Jurnal Pengembangan Energi Nuklir. 15, pp. 69-79.

Duderstadt J. J. 1976. Nuclear Reactor Analysis. New York: John Wiley and Sons.

GIF. 2002. A technology roadmap for generation IV nuclear energy systems.

GIF. 2020. 2020 Annual Report. Paris.

Ilham M., Raflis H. and Suud Z. 2020. Full Core Optimization of Small Modular Gas-Cooled Fast Reactors Using OpenMC Program Code. Journal of Physics: Conference Series, 1493(1). doi:10.1088/1742-6596/1493/1/012007.

Ilham M. and Su'ud Z. 2017. Design Study of Modular Nuclear Power Plant with Small Long Life Gas Cooled Fast Reactors Utilizing MOX Fuel. Journal of Physics: Conference Series, 755(1): 5-9. doi:10.1088/1742-6596/755/1/011001.

Irka F. H. *et al.* 2021. Neutronics performances of gas-cooled fast reactor for 300-600 MWt Output Power with Modified CANDLE burn-up scheme in radial direction. Journal of Physics: Conference Series, 2072(1). doi:10.1088/1742-6596/2072/1/012013.

Okumura K. *et al.* 2002. SRAC (Ver.2002); The comprehensive neutronics calculation code system. Japan: Japan Atomic Energy Research Institute (JAERI).

Okumura K. 2007. COREBN: A Core Burn-up Calculation Module for SRAC2006. Japan Atomic Energy Agency. 53(9): 1689-1699.

Syahputra T. S., Razak A. and Su'ud Z. 2020. Study of Modified CANDLE Burnup Scheme in a Helium Cooled Fast Reactor Using Uranium-Plutonium Nitride. Journal of Physics: Conference Series, 1493(1). doi:10.1088/1742-6596/1493/1/012013.

Syarifah R. D. *et al.* 2016. Design Study of 200MWth Gas Cooled Fast Reactor with Nitride (UN-PuN) Fuel Long Life without Refueling. MATEC Web of Conferences, 82, pp. 0-5. doi:10.1051/mateconf/20168203008.

Syarifah R. D. *et al.* 2017. Fuel Fraction Analysis of 500 MWth Gas Cooled Fast Reactor with Nitride (UN-PuN)

Fuel without Refueling Fuel Fraction Analysis of 500 MWth Gas Cooled Fast Reactor with Nitride (UN-PuN) Fuel without Refueling. Journal of Physics: Conference Series [Preprint]. doi:10.1088/1742-6596/755/1/011001.

Syarifa R. D. *et al.* 2020. Actinide Minor Addition on Uranium Plutonium Nitride Fuel for Modular Gas Cooled Fast Reactor', Journal of Physics: Conference Series, 1493(1). doi:10.1088/1742-6596/1493/1/012020.

Syarifah R. D. *et al.* 2021. Analisis Fraksi Volume Bahan Bakar Uranium Karbida Pada Reaktor Cepat Berpendingin Gas Menggunakan SRAC Code. Jurnal Jaring SainTek, 3(1): 13-18. doi:10.31599/jaring-saintek.v3i1.333.