

Digital Repository Universitas Jember

International Journal Of Innovation, Creativity and Change



Volume 11, Issue, 2 March, 2020

ISSN 2201-1315

Editorial Board

Editorial Board members work together by consensus to provide IJICC with editorial direction in the following areas: Identify scope of journal content and, when appropriate, themes for various issues. Determining Criteria for accepting manuscripts for publication consideration. Developing criteria and guidelines for reviewers to use in reviewing each type of manuscript Developing criteria and guidelines for authors to use in creating each type of manuscript Reviewing manuscripts as needed and appropriate. Soliciting manuscripts from potential authors. Promoting IJICC to potential authors, readers and indexers.

Dr Tina Doe

Journal Editor

Dr

**Muhammad
Haseeb**

Associate Editor

Professor

**Richard
Smith**

Senior Reserach
Officer Southern
Cross University



(<https://twitter.com/doetinadoe>)



(<https://au.linkedin.com/in/tinadoe>)

Senior Lecturer,
Taylor's Business
School, Taylor's
University, Malaysia

Emeritus Professor
of Education, Central
Queensland
Univeristy Chair,
Board of Australian
Institute of Music

Digital Repository Universitas Jember

**Professor
Iwao
Shibata**

Managing Director,
Business
Breakthrough, Inc.
Japan

**Professor
Bruce
Knight**

Professor of
Education, Central
Queensland
University

**A/Prof.
Catherine
O'Brien**

Associate Professor
of Education Cape
Breton Univeristy,
Canada

Professor, Graduate
School of
Management, BBT
University, Japan.

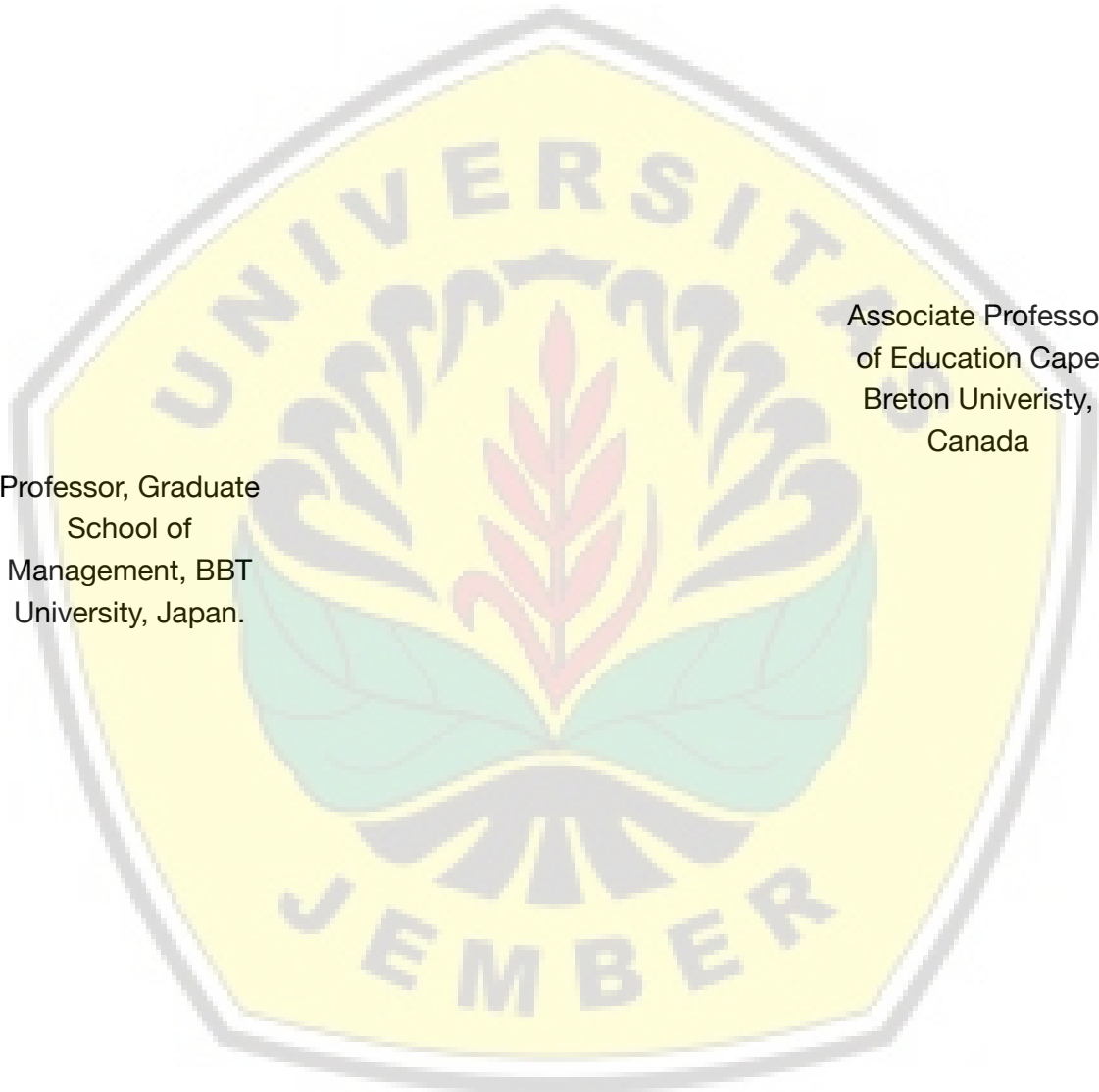

**Dr. Rick Van
der Zwan**

Cognitive Neuro-
scientist Consultant

**Professor
David
Spendlove**

**Dr. Abraham
Francis**

Senior Lecturer
Department of
Social Work and
Human Service



Director, Teaching
and Learning,
Manchester Institute
of Education The
University of
Manchester.

**Professor
DOU Qin**

**Dr Eric F.
Eshun**

**Professor
David Lynch**

**Southern Cross
University, Australia**

Professor DOU Qin
Dean, Dept. of
Languages
Northwest A&F
University Yangling
Shaanxi, China

Senior Lecturer
Kwame Nkrumah
University of Science
& Technology Ghana

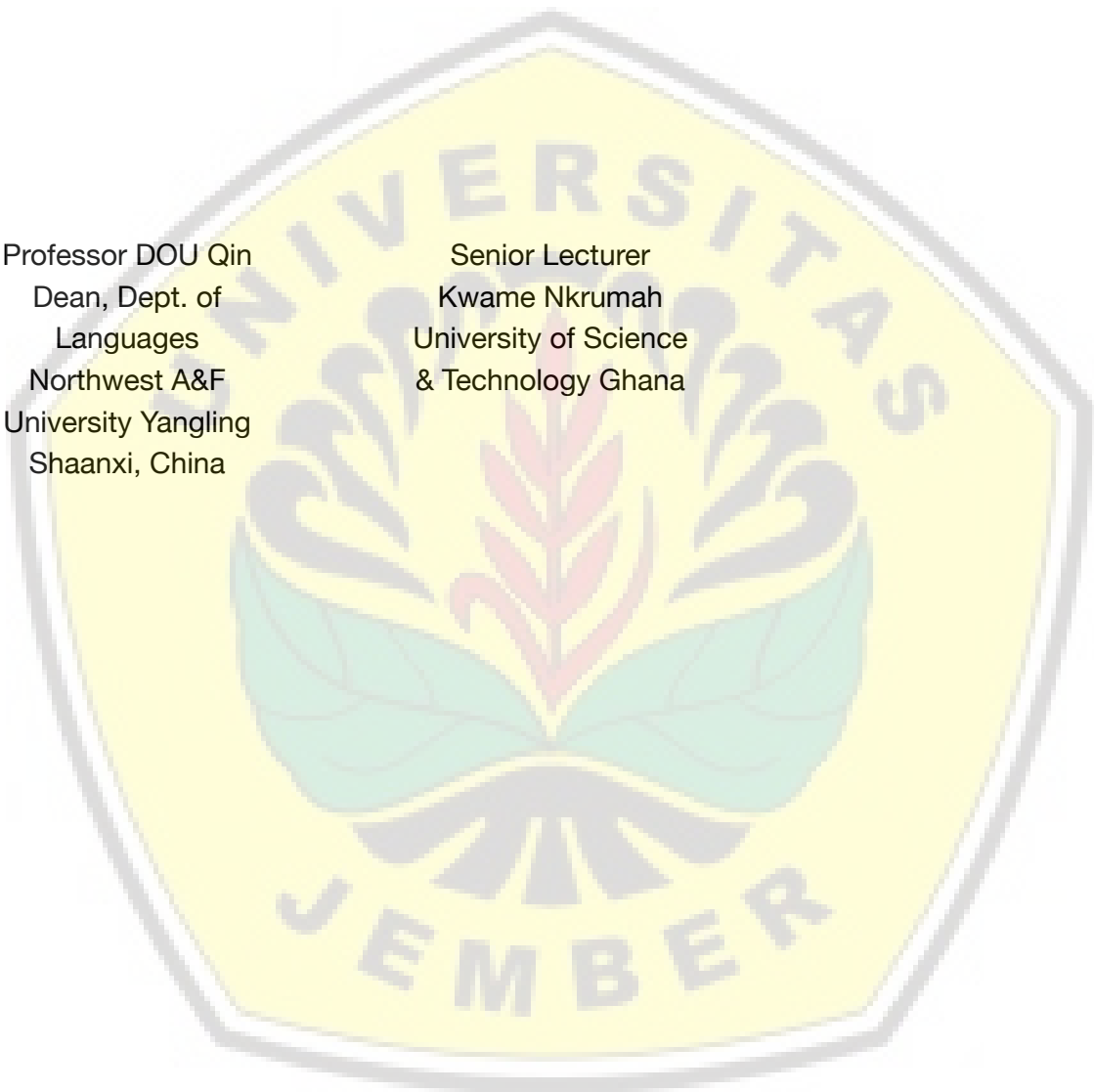

Dr.LI Xuan

**Professor
Greg
Whateley**

Tumpa Dey

Academic (retired)

Lecturer (Human
Resource
Management and
International
Education) Central
Queensland
Univeristy

Assistant Professor
Organisational
Behaviour and
Human Resources
IMT Hyderabad



Digital Repository Universitas Jember

**Dr. Jake
Madden**

Principal, Al Yassat
Private School, Abu
Dhabi, UAE

**Dr Lorna
Hallahan**

Senior Lecturer,
Social Work and
Social Planning Fli

**Ms. Maree
Garrigan**

Executive Northern
Territory Department
of Education



Senior Lecturer,
Social Work and
Social Planning
Flinders University
SA

**Dr Prudence
Millear**

**Dr Mark
Sinclair**

**Dr Cecily
Knight**

Senior Lecturer
Teacher Education
Program University
of Te

Senior Lecturer and
Academic
Development
Advisor James Cook

Lecturer in
Psychology
University of the
Sunshine Coast,
Australia. FAB Prue
Millear



Digital Repository Universitas Jember

**Dr Terry
Quong**

Principal Jockey
Club Ti-I College,
Hong Kong (ret)

Mr. Ken Sell

Head of School
Aoba-Japan
International School
Tokyo, Japa

**Dr Santosh
Kumar
Behera**

Department of
Education, Sidho-
Kanho-Birsha
University, West

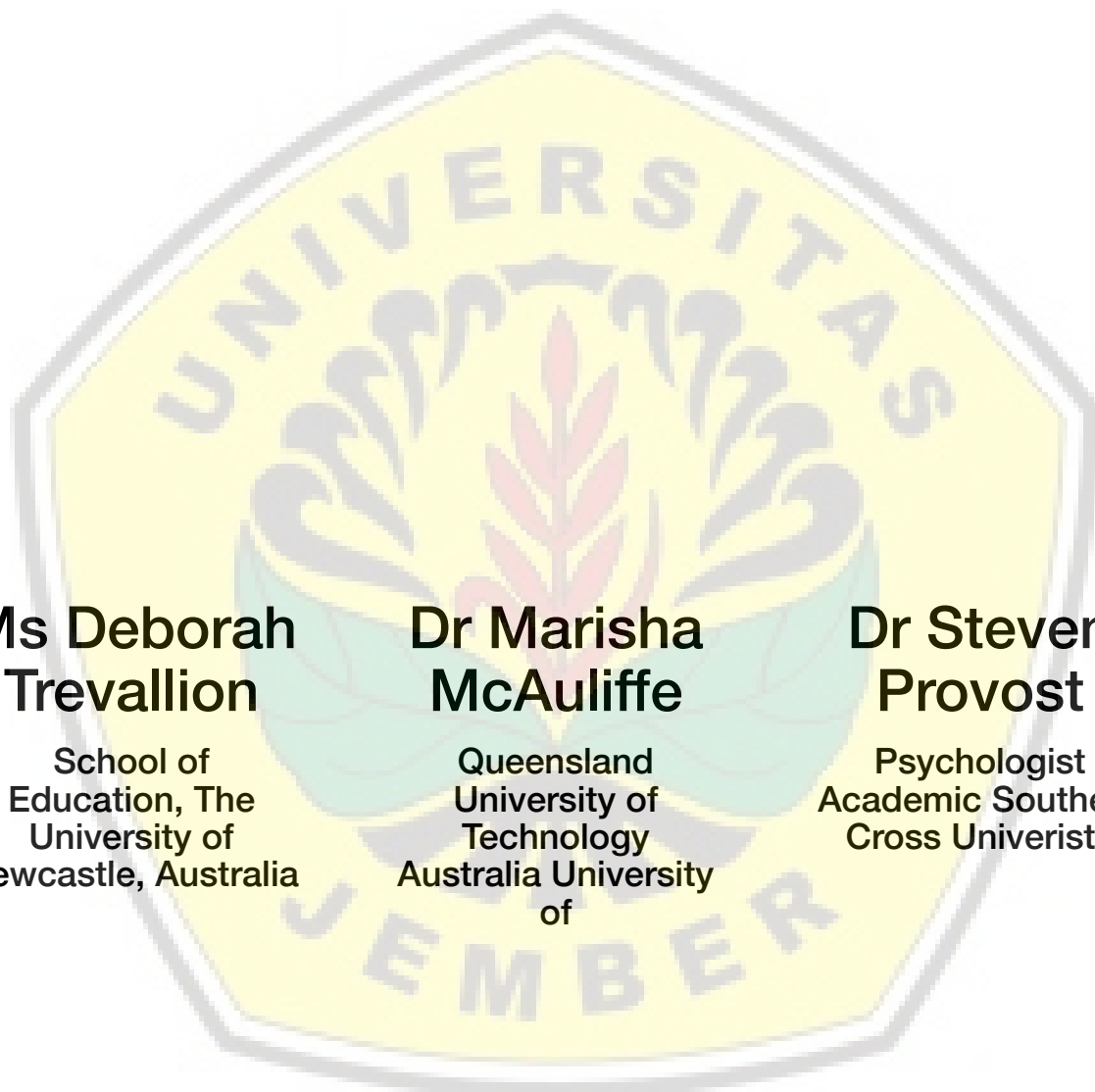

**Ms Deborah
Trevallion**

School of
Education, The
University of
Newcastle, Australia

**Dr Marisha
McAuliffe**

Queensland
University of
Technology
Australia University
of

**Dr Steven
Provost**

Psychologist
Academic Southern
Cross Univeristy

Digital Repository Universitas Jember

**Dr Teemu
Ylikoski**

Director Regional
Services Laurea
University of
Applied Sci

**Dr David
Turner**

Director
Professional
Learning
Queensland
Association of St

Cathy Quinn

Education
Consultant Aakorn
Management
Australia



**Shane
Mason**

Deputy Principal
Cleveland District
State High School
Quee

**Dr Pam
Watters**

Dr. Pamela Watters
Office of Diversity,
Inclusion, and
Comm

**Dr Venkat
Pulla**

Coordinator, Social
Work Discipline
Australian Catholic
Uni

**Dr
Margaret-
Anne Carter**

Discipline Chair for
Counselling
Australian College
of app

**Eko
Susanto**

Head of Scientific
Publication Unit
Universitas
Muhammadiyah

**Associate
Professor
Armend
Tahirsylaj**

Associate Professor of
Education
Department of
Teacher Educa



Dr Jason Sawyer

Assistant Professor
The Ethelyn R.
Strong School of
Social W

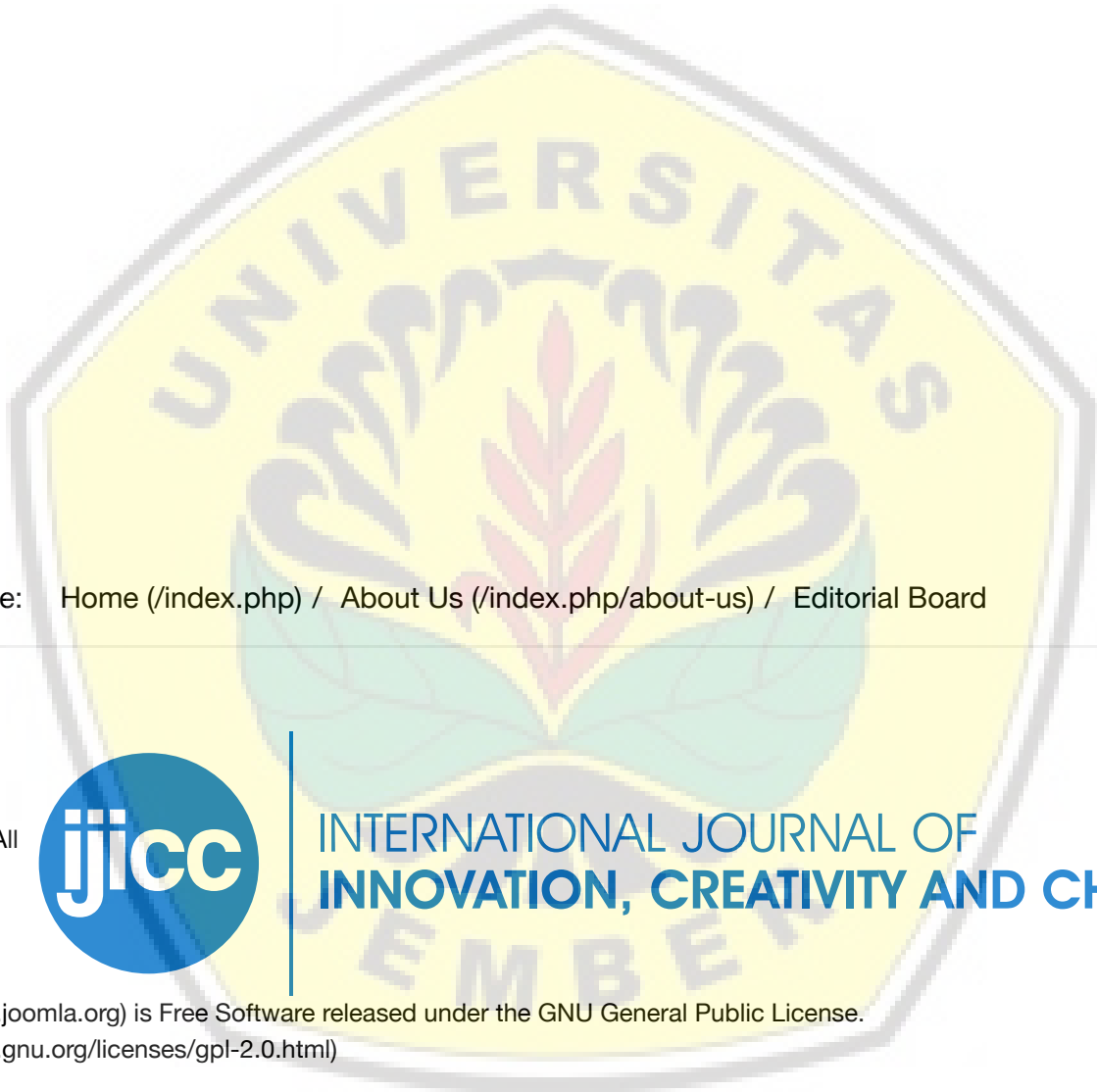

You are here: [Home \(/index.php\)](#) / [About Us \(/index.php/about-us\)](#) / [Editorial Board](#)

(/.)

Copyright ©
2020 IJICC. All
Rights
Reserved.
Joomla!



INTERNATIONAL JOURNAL OF
INNOVATION, CREATIVITY AND CHANGE

(<https://www.joomla.org>) is Free Software released under the GNU General Public License.
(<https://www.gnu.org/licenses/gpl-2.0.html>)



The Effect of Professionalism, Auditors Human Resource Competency and Executive Follow Up Commitment on Internal Auditors Performance

Erwin Hadisantoso^a, Made Sudarma^b, Mediaty^c, Yohanis Rura^d,
Kurniaty^e, Arnis Budi Susanto^f, ^aHalu Oleo University, ^bBrawijaya
University, ^{c,d,e}Hasanuddin University, ^fUniversity of Jember, Email:
^aerwinhadisantoso@uho.ac.id, ^bmade@mtd.co.id,
^cunhasmediaty@gmail.com, ^drurayohanis@fe.unhas.ac.id,
^ekurniaty@pasca.unhas.ac.id, ^farnis.feb@unej.ac.id

This study aims are to test and analyse (i) the effect of auditors professionalism on internal auditors performance; (ii) the auditors human resources competence on internal auditors performance; (iii) the executive follow-up commitment on auditors performance; (iv) the auditors human resources competence on auditors performance through the auditors spirituality dimension; and (v) the executive follow-up commitment on auditors performance through the auditors spirituality dimension. This is an explanatory research with a quantitative approach. The population is internal auditors and Supervisors at a Local Apparatus Work Unit (LAWU). Samples are 172 auditors. Data was collected by questionnaires and analys using a structural equation model (SEM) with AMOS software, 21.0. The research results showed that auditors professionalism and auditors human resource competence have insignificant effect on auditors performance. Executive follow-up commitment has a significant effect on auditors performance. Auditors HR competence has significant effect on auditors performance through spirituality variables. Executive follow up commitment has significant effect on auditors performance through auditors spirituality.

Key words: *Professionalism, auditors human resourced competence, executive follow-up commitment, spirituality, and internal auditors performance.*



Introduction

Debates on methods and factors affecting an auditors performance are important considerations, especially if the auditors performance is related to public organisation. Brazel et al. (2004) describes the method of work paper as an effective alternative method to determine high auditors performance; while Leewu (1992) evaluates the auditors performance through similarities and dissimilarities methods of policy evaluation. Evaluating auditors performance in the public sector aims to provide better services and to minimise the various costs and allocations of human resources behaviour (Funnell, 1997).

Internal auditors have a supervisory arrangements scope in workplace, i.e. institutional, duties scope, human resources competence, auditors standards, auditors code of ethics, reporting, and peer review. The guidance of internal audit consists of preparation of technical guidelines for organisation, socialisation, education and training, guidance and consultation, as well as the improvement of internal auditors competence in each local government agency. Internal auditors are needed to report the examination results to BPK. The auditors tasks are not limited to examination scope but also service and consultation functions as efforts to improve the performance of local government.

The professionalism concept developed by Hall (1968) found that professionals see their profession as reflected in their attitudes and behaviour. Kalbert and Fogarty (1995) studies used the concept proposed by Hall (1968) to formulate five professional elements (Hall Taxonomy); (1) community affiliation; (2) autonomy demand; (3) belief on self-regulation; (4) dedication; and (5) social obligation. This study examines the relationship of professionalism, performance, job satisfaction, organisational commitment, willingness to move, and experience of 455 internal auditors in various industries in the United States. The results showed that professionalism had no significant effect on job satisfaction.

Research by Boyt et al. (2001) and Shafer et al. (2002) found different results that professionalism greatly affect performance. The appreciation structure for professionalism attitudes directly leads to higher job satisfaction and performance. Different findings on the relationship between professionalism with job satisfaction and performance shows that inconsistency is a gap for researchers to conduct research.

The research results of auditors of human resources competence findings become debates. Nuryanto and Afiah (2013) and Octavia and Widodo (2015) revealed that competence can effectively improve the internal auditors performance. Darwanis and Mahyani (2009), explained that human resource capacity affects the reliability of local government financial reporting. The internal auditors competence is characterised by increased knowledge, skills, and previous work experience. Competence is largely determined by intellectual ability and



physical ability. However, other research found different results. These many shortcomings can be used as the basis to examine low performance auditors in local government.

The executive follow-up commitment is a critical determinant of internal auditors performance. Novyarni (2014) examines the executive follow-up commitments and governmental organisations in relation to auditors performance. Similar findings were also presented by Silviana and Zahara (2015) that executive follow-up commitment had a significant effect on internal auditors performance. Claude and Zamor (2003) and Beheshtifar and Zare (2013) also examine the executive follow-up commitments on internal auditors performance, confirming that increased executive follow-up commitments can create auditors with integrity and dedication.

Internal auditors performance issues are complex and are determined by various empirical factors such as professionalism, human resource competence, and executive follow-up commitments. In addition, spirituality dimensions is another urgent factor to explain the auditors performance in the local government inspectorate. The construct of the spirituality dimension is based on two aspects namely intelligence spirituality and workplace spirituality.

The spirituality dimension will allow one to think creatively, insightfully make and even change the rules. Thus, spirituality intelligence is the basis for effective function of intellectual intelligence and emotional intelligence. Zohar and Marshal (2000) said that spirituality intelligence could make a man intact intellectually, emotionally and spiritually. Therefore, auditors must be able to use their spirituality dimension to make a decision to produce a better and meaningful performance in life.

Internal auditors usually find obstacles in implementation, due to a strong sense of kinship, togetherness, and humane considerations or even, some chief executive pressure. Another problem to improve the role of internal auditors is how to improve the attitudes or behaviour of internal auditors in conducting the examination to make effective and efficient reporting and monitoring. Therefore, this study is intended to deepen the professionalism, auditors human resource competence, executive follow-up commitment and the effect on auditors spiritual and internal auditors performance at provincial and district governments in Southeast Sulawesi.

In Southeast Sulawesi Province, viewed from Audit Report (LHP) of Supreme Audit Board (BPK-RI) of Southeast Sulawesi Representative for district/municipality government financial report, and provincial government of Southeast Sulawesi Fiscal Year 2014 and 2015 not all regions have received the best financial management predicate an "Unqualified Opinion" statement. There are only four local governments in 2014 with Unqualified Opinion and six local governments in 2015. This data shows a problem that occurs at the executive



side. The internal auditors role as part of the executive becoming the initial filter to produce good Local Apparatus Work Unit (LAWU) has not shown positive results.

This research is based on a condition that general studies of performance always relate to intellectual and emotional abilities of individuals and do not exactly explain how individuals satisfaction to achieve the best performance in public sector organisations. This research examines the concept of developing a theoretical model to test the relationship of professionalism, human resource competence, follow up executives commitment on spirituality dimensions and internal auditors performance. This study aims are to test and analyse (i) the effect of auditors professionalism on internal auditors performance; (ii) the auditors human resources competence on internal auditors performance; (iii) the executive follow-up commitment on auditors performance; (iv) the auditors human resources competence on auditors performance through the auditors spirituality dimension; and (v) the executive follow-up commitment on auditors performance through the auditors spirituality dimension.

Literature Review

Auditors Professionalism

Hall (1968) said that professionalism is used to measure how professionals' view their profession as reflected in their attitudes and behaviour. Hall (1968) considers a reciprocal relationship between professionalism attitudes and behaviours as a reflection of professionalism, and vice versa (Kalbers and Fogarty, 1995).

The professional elements used in this study were developed by Kalbers and Forgaty (1995), namely: (1) to ensure that work is very important; (2) have confidence to provide services to public; (3) autonomy in doing the work; (4) advocating its own rules in work; and (5) affiliating with same peer work in other organisations.

Internal Auditors Competence

Guy et al. (2002) said that competence is the knowledge and skills needed to complete the task. Competence as an individuals' characteristic contributes to successful work performance and organisational output (Sinnott et al., 2002). Competence can be understood as a combination of skills, personal attributes, and knowledge reflected through performance behaviours that can be observed, measured and evaluated.

The role of internal auditors is more important along with a more complex of government system. Without internal auditors, a government unit head does not have an independent,



internal source of information about the organisation's activities, governmental organisations or other organisations. Sawyer et al. (2003) noted that unattended activity would lose its efficiency and effectiveness. Internal audits have split off into disciplines with a wider focus of attention. Modern internal auditors provide services such as internal control assessments, administrative fields and financial statements (Birkett et al., 1977).

Executive Follow-up Commitment

The executive follow up commitment is the commitment of local government to fulfil the firm attitude and self-consistency to reach the specified targets to examine the result of both internal and external auditors. This attitude can be identified by how auditors manage all issues and find the best solution for local government management. The local governments have a responsibility to manage and monitor all aspects of regional finance that well, accountable and transparent.

The audit report will be effective if there is a follow-up to ensure that audit process is really beneficial to a company. Tugiman (2000: 75) suggested that "Follow-up by an internal examiner is defined as a process to determine the adequacy, effectiveness, and timeliness of various actions performed by management on reported findings of investigations". These activities are known as audit results follow-up monitoring.

Dimension of Auditors Spirituality

Spirituality comes from the term "spiritus" or "spiritualist" which means breathing, breath, air or wind. Spiritus is defined as "animate or vital principle to give life to a physical organism". This implies that spirit is the life force that inhabits us when we are alive and breathing (Garcia-Zamor, 2003). As defined by Mitroff and Denton (1999a), "Spirituality is the desire to find the ultimate goal in life and life based on that purpose".

Janfeshan et al. (2011) explained that spirituality is an inherent intrinsic human characteristic that does not infer religious meaning. Spirituality in a broad sense is not an optional quality that we may choose. Everyone has a spirit, even if the person is atheist, nihilistic or materialistic. Spirituality is an element within each individual and spirituality cannot be separated from individual (Campuzano and Seteroff, 2009). Mitroff and Elizabeth Denton, author of "A Spiritual Audit of Corporate America", describe their view on spirituality as informal and personal, primarily concerned with individual. They also see spirituality as universal, non-denominational, broad, inclusive, and tolerant, and as "a basic feeling of being connected to complete self of one person, another, and whole universe".



Auditors Performance

Performance is closely related to purpose, as a result of one's work behaviour (Davis & Newstrom, 1985). Behavioural performance can be traced down to specific factors such as ability, effort and task difficulty. Performance is a result of actions pattern taken to achieve the objectives consistent with standards of achievement, qualitative and quantitative, which has been established by individuals or by companies where individuals work.

Robbins & Judge (2008) said that performance is determined by ability, motivation and opportunity factors. Opportunities are intended at high performance levels, and partly a function of obstacles absence to control the employee. Performance to perform the function does not stand alone, but relates to job satisfaction and rewards, skills, and individual traits. Kalbers and Fogarty (1995) describe the dominant dimensions of professionalism affecting performance, namely: the dimensions of community affiliation and autonomy demands, professionalism dimension of community affiliation is positively related to job satisfaction. Rahmawati (1997) found that all dimensions of professionalism are significantly related to auditors performance.

Conceptual Framework and Hypotheses

Conceptual Framework

Internally induced behaviour is a behaviour under the personal control of the individual. External behaviour is seen as a result of external causes of being forced to behave because of the situation (Robbins et al., 2003). The causes of behaviour in social perception are known as dispositional attribution and situational attribution or internal and external causes (Robbins et al., 2003). Disposition attribution or internal causes refer to aspects of individual behaviour, something within a person such as the personal nature of self-perception, motivational ability, including professionalism and locus of control attitude. Situational attribution refers to an environment to affects behaviour, such as social conditions, social values, societal views including spirituality in workplace. The relationship between these variables can be seen in Research Framework at Figure 1 below.



Figure 1. Research Framework

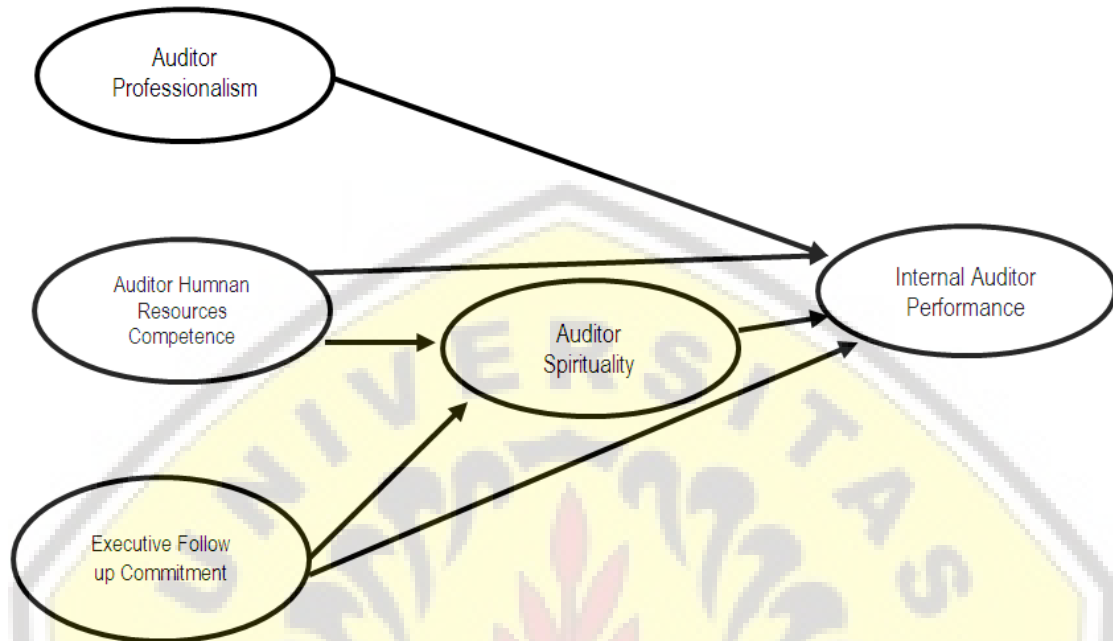

Hypothesis

Based research objectives and conceptual framework, the research hypotheses are listed below.

1. Hypothesis 1 (H1): Auditors Professionalism has positive effect on internal auditors performance.
2. Hypothesis 2 (H2): Auditors human resource competence has positive effect on internal auditors performance.
3. Hypothesis 3 (H3): Executive follow-up commitment has positive effect on internal auditors performance.
4. Hypothesis 4 (H4): The human resources competence has positive effect on auditors spirituality dimension.
5. Hypothesis 5 (H5): the Executive follow-up commitment has positive effect on spirituality dimensions.
6. Hypothesis 6 (H6): The human resources competence has positive effect on auditors performance through the auditors spirituality dimension.
7. Hypothesis 7 (H7): The Executive's Follow-up Commitment has positive effect on internal auditors performance through the spirituality dimensions.
8. Hypothesis 8 (H8): The spirituality dimension has positive effect on internal auditors performance.



Research Methods

This is explanatory research and a quantitative approach is used to analyse the data. This research was conducted at Local Government in Southeast Sulawesi, involving a whole 13 of 17 districts/cities and provinces in Southeast Sulawesi. The study begins in September 2016 until December 2016.

The study population is the internal auditors and supervisor of Local Apparatus Work Unit (LAWU) of Regional Inspectorate at Local Government in Southeast Sulawesi, consisting of 13 districts/municipalities and provinces that have long been established and not a new District or New Autonomous Region. Each district, city and province has 15-30 internal auditors and supervisors totalling approximately 250 people. The sample in this study is the internal auditors and supervisory inspectorate area of 182 people and spread in 13 LAWU. Data was collected by 182 questionnaires and some respondents were willing to be interviewed directly to support this research.

Data analysis method used is descriptive statistical analysis data tabulation in table and conducted descriptive discussion. It also uses inferential statistical analysis to analyse sample data. The results taken can be applied to a population. An inferential statistical technique uses SEM (Structural Equation Model).

Research Results

Respondents Characteristics

Respondent characteristics are explored by sex, age, last education level, and years of service. Each respondent studied has several characteristics described as follows.

Table 2: Respondent Characteristics

No.	Description	Frequency	Percent
	Gender		
1	Male	98	57,0
2	Female	74	43,0
	Total	172	100
	Age		
1	< 30 year	64	37,2
2	> 31 year	108	62,8
	Total	172	100
	Last Education Level		
1	Diploma	0	0



2	Scholar	103	59,9
3	Magistrate	69	40,1
4	Doctor	0	0
	Total	172	100
	Work duration		
1	< 7 years	48	27,9
2	≥ 7 years	124	72,1
	Total	172	100
	Ever followed training		
1	JFA Training	25	14,62
2	Bintek Audit	82	47,95
3	Bintek Review	64	37,43

Source: Data Results (2016)

The respondents consisted of males (57.0%) and females (43.0%). This condition shows the higher role of men in world work, especially as internal auditors. The age consists of less than 30 years (37.2%) and more than 31 years (62.8%). The respondents aged over 31 years is dominant in this study. The last education is bachelor (59.9%) and magistrate (40.1%). Work experience of internal auditors has a normative effect on way of thinking or action as a result of formal education.

The tenure less than 7 (seven) year 27.9%, while the tenure 7 years or above is 72.1%. The tenure 7 years or above shows the work experience of auditors who are able to support the quality achievement in work. Based on level of education and training that has been followed and work period of respondents, it is expected that all APIPs in district/city inspectorate office in Southeast Sulawesi Province in this research have a sufficient level of understanding and knowledge to answer the statements in research instrument.

Full Model Research Tests

Full model test classify variables into exogenous and endogenous variables. The result of SEM analysis is shown in figure 2 below.



Figure 2. Models Measurement of Variables Relationship

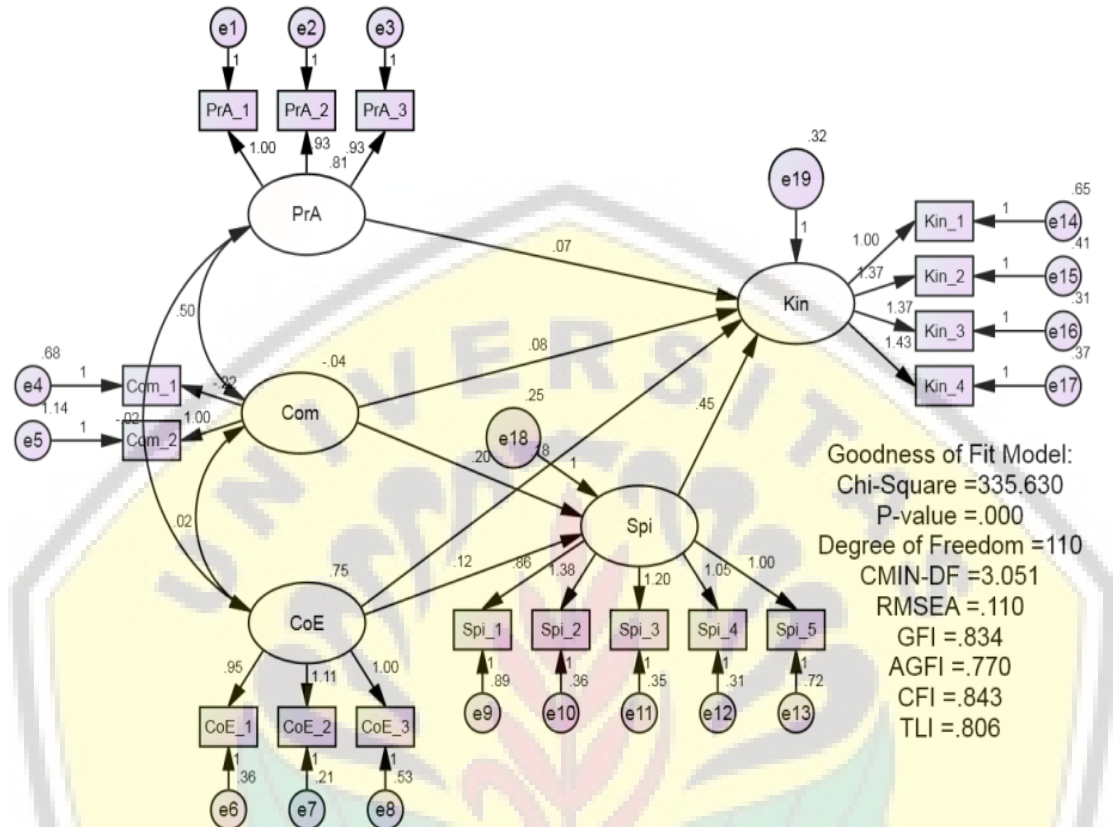

Figure 2 evaluates the model based on goodness of fit indices in table 3 below to show model criteria and critical value of data suitability.

Table 3: Evaluation of Overall Model

Goodness of fit index	Cut-off Value	Model Results	Description
X2 Chi Square	$\alpha = 5\% \rightarrow 135,480$	335,630	Less Good
Probabilities	≥ 0.05	0.000	Less Good
CMIN/DF	≤ 2.00	3.051	Less Good
RMSEA	≤ 0.08	0.110	Less Good
GFI	≥ 0.90	0.834	Less Good
AGFI	≥ 0.90	0.770	Less Good
TLI	≥ 0.95	0.806	Less Good
CFI	≥ 0.95	0.843	Less Good

Source: Data Processed (2016)

Table 3 shows all criteria of goodness of fit indices do not meet the criteria, therefore, the model is not feasible to use. Based on modification indices instructions in the AMOS



program, then modifications are made to correct the model. Model modification is preferred only to correlate between items or errors and does not modify the path of effect. Structural model test results after following the modification indices instructions then obtained the following results.

Figure 3. Relationship Variable (Modified)

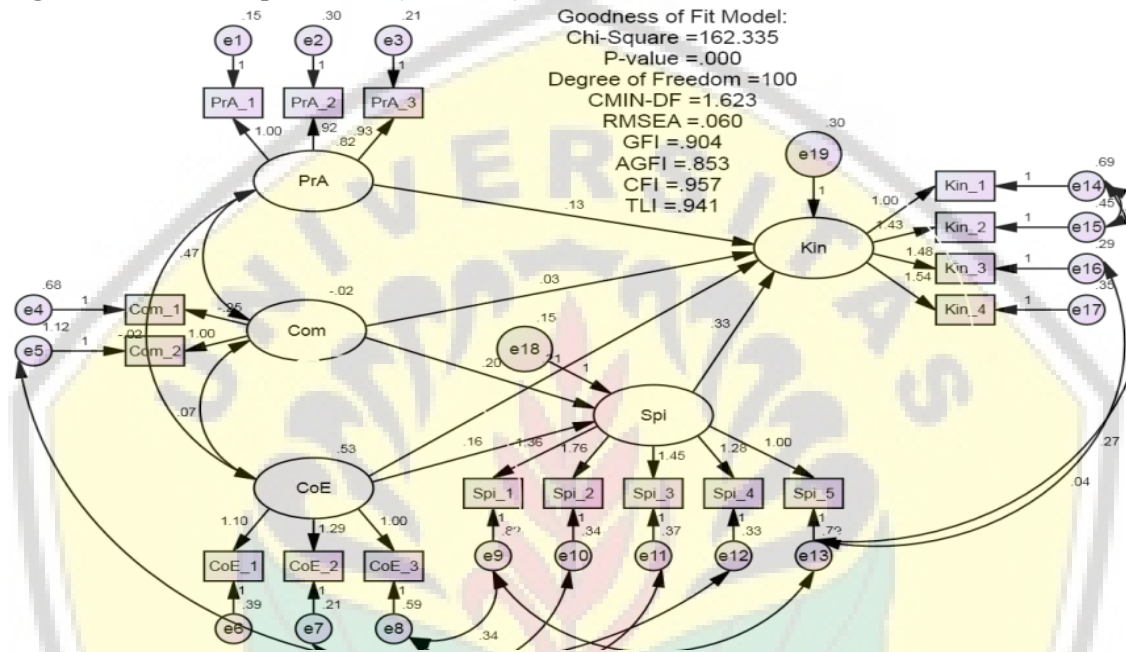

Figure 2 shows the test result after modification. Evaluation of the goodness of fit indices in table 4 below shows the model criteria and critical value (cut-off value) for data suitability.

Table 4: Evaluation of Overall Model Criteria After Modification

Goodness of fit index	Cut-off Value	Model Result	Description
X2 Chi Square	$\alpha = 5\% \rightarrow 124,342$	162,335	Less Good
Probabilities	≥ 0.05	0.000	Less Good
CMIN/DF	≤ 2.00	1.623	Good
RMSEA	≤ 0.08	0.060	Good
GFI	≥ 0.90	0.904	Good
AGFI	≥ 0.90	0.853	Marginal
TLI	≥ 0.95	0.941	Marginal
CFI	≥ 0.95	0.957	Good

Source: Data Processed (2016)



Table 4 shows that some goodness of fit criteria of CMIN-DF, RMSEA, GFI, and CFI has met the cut-off value standard. Therefore, the research model is considered fit. The causality developed in the hypotheses are tested by a t-test (critical ratio). Table 4 shows the regression weight estimate and critical ratio (t arithmetic) values. The hypothesis will be accepted if the critical ratio (t arithmetic) is greater than 1.960 or the p value ≤ 0.05 .

Table 4 also analyses the functional relationships between exogenous variables (auditors professionalism, auditors human resource competency, and executive follow-up commitment) and endogenous variables (spirituality dimension, and auditors performance). The estimated value, t-count, and p-value values are shown in table 5 below.

Table 5: Recapitulation of the Effect among Variables

Variables	Variables	Direct Effect		
		Estimate	Critical Ratio	P-Value
Auditor Human Resource Competence	Spirituality Dimension	0.201	2.345	0.019
Executive Follow up Commitment	Spirituality Dimension	0.125	2.091	0.037
Professionalism	Auditors performance	0.070	0.759	0.448
Auditor Human Resource Competence	Auditors performance	0.075	0.653	0.514
Executive Follow up Commitment	Auditors performance	0.180	2.754	0.006
Spirituality Dimension	Auditors performance	0.451	3.281	0.001
Independent variables	Intervening variables	Dependent variables	Indirect Effect Standardized	
Auditor Human Resource Competence	Spirituality Dimension	Auditors performance	0.056	
Executive Follow up Commitment	Spirituality Dimension	Auditors performance	0.091	

Source: Data Processed (2016)

Table 5 shows the factors loading in structural model. The functional relations of exogenous and endogenous variables can be described below.



1. The effect of auditors human resource competence on the spirituality dimension has an estimated value of 0.201 or 20.1 percent. It shows that with improvement of auditors, human resource competence quality will affect to increase spirituality dimension, with the assumption that other factors are constant. The coefficient value of auditors spirituality dimension reflects the high contribution of auditors human resource competence to determine the high dimension of auditors spirituality dimension.
2. Effect of executive follow-up commitment on spirituality has an estimated value of 0.125 or 12.5 percent. These values indicate that higher quality of executive follow-up commitment will have an effect to increase spirituality dimensions with assumption that other factors are constant. Spirituality dimensions are considered constant. The coefficient value of executive follow-up commitment on spirituality dimension reflects the high contribution of executive follow-up commitment quality to determine the high dimension of auditors spirituality dimension.
3. The effect of professionalism on auditors performance based on estimated value is 0.070 or 7.0 percent. This value shows that improvement of professionalism quality will not affect an auditors performance improvement; with the assumption that other factors are constant.
4. The effect of auditors HR competence on auditors performance is based on an estimated value of 0.075 or 7.5 percent. This value shows that quality improvement of auditors human resource competency will not have an effect on auditors performance improvement with the assumption that other factors are constant.
5. The effect of executive follow-up commitment on auditors performance based on an estimated value is 0.180 or 18.0 percent. This value shows that quality improvement of executives follow-up commitment will have an effect on auditors performance improvement with the assumption that other factors are considered constant. The magnitude of the coefficient value of an executive follow-up commitment quality on auditors performance reflects the high contribution of executive follow-up commitment quality in determining the auditors performance.
6. The effect of spirituality dimension on auditors performance is based on an estimated value of 0.451 or 45.1 percent. This value shows that quality improvement of the spirituality dimension will affect improvement of auditors performance with assumption that other factors are considered constant. The coefficient value of the spirituality dimension variable on auditors performance reflects the high contribution of quality spirituality dimension in determining the high auditors performance.
7. The indirect effect of auditors human resource competence on auditors performance by considering the spirituality dimension shows a positive and significant effect. It is explained that developing human resource competence will improve the auditors performance if accompanied by increased spirituality dimensions.
8. The indirect effect of executive follow-up commitment on auditors performance by considering the spirituality dimension shows a positive and significant effect. It is



explained that by developing a better follow-up executive commitment it will improve the auditors performance if accompanied by an increase in the spirituality dimension.

This research hypothesis can be accepted or rejected based on the statistical test with a standard value of critical ratio (C.R) or t value of ≥ 1.96 and p-value ≤ 0.05 . The research results are described below.

- a. The effect of auditors professionalism on auditors performance is shown by the critical ratio value (t-count) of 0.759 compared with standard significance value of 0.448. It shows that auditors professionalism does not have significant effect on auditors performance. Therefore, the first hypothesis (H-1) is rejected.
- b. The effect of auditors human resource competence on auditors performance is shown by critical ratio value (t-count) of 0.653 compared with standard significance value of 0.514. It shows that auditors human resource competence does not have a significant effect on auditors performance. Therefore, the second hypothesis (H-2) is rejected.
- c. The effect of executive follow-up commitment on auditors performance is shown by the critical ratio value (t-count) of 2.754 compared with standard significance value of 1.960. It shows that executive follow up commitment has significant effect on performance auditors. It is interpreted that strengthening executive follow-up commitment also affected auditors performance. Therefore, third hypothesis (H-3) is accepted.
- d. The effect of auditors human resource competence on spirituality dimension is shown by critical ratio value (t-count) of 2.345 compared with standard significance value of 1.960. It shows that auditors human resources competence has a significant effect on the spirituality dimension. It is interpreted as the effect of strengthening human resource competence auditors also affect the spirituality dimension. Therefore, the fourth hypothesis (H-4) is accepted.
- e. The effect of executive follow-up commitment on spirituality dimension is indicated by the critical ratio (t-count) of 2.091 compared with standard significance value of 1.960. It shows that executive follow-up commitment has significant effect on the spirituality dimension. It is interpreted as the effect of strengthening executive follow-up commitment also affect the spirituality dimension. Therefore, the fifth hypothesis (H-5) is accepted.
- f. The indirect effect of auditors human resource competence on auditors performance through spirituality dimension variable is indicated by standardised indirect effect value of 0.056. It shows a significant effect between auditors human resource competence on auditors performance through spirituality dimension. Therefore, the sixth hypothesis (H-6) is accepted.
- g. The indirect effect of executive follow-up commitment on auditors performance through the spirituality dimension is indicated by standardised indirect effect value of 0.091. It shows that executive follow-up commitment affect on auditors performance through the spirituality dimension variable. Therefore, the seventh hypothesis (H-7) is accepted.



- h. The effect of spirituality dimension on auditors performance is shown by critical ratio value (t-count) of 3.281 compared with standard significance value of 1.960. It shows the spirituality dimension has significant effect on auditors performance. Therefore, the eighth hypothesis (H-8) accepted.

Discussion Research

The Effect of Auditors Professionalism on Internal Auditors Performance

The research findings show that the auditors professionalism has no significant effect on internal auditors performance. This finding has some similarities to previous research results. Schroeder and Imdeke (1977) examine 172 public accountants in 16 organisations in the United States. They who found that professionalism is not related to company size and negatively related to auditors job satisfaction. Similarly, Kalbers and Fogarty (1995) found that there are only two dimensions of professionalism that are positively related to performance, namely community affiliation and autonomy demands, while the dimensions of belief in profession rules, dedication, and social obligations negatively affect performance.

Other studies that are consistent with the results of this study are Gede Bandar Wira Putra (2013) that professionalism and role vagueness has no significant effect on auditors performance. Furthermore, Akhmad Riduwan (2012) concluded that work experience negatively affect quality of examination. Herliansyah and Ilyas (2006) found that experience reduces the effect of irrelevant information on judgment auditors. The results of this study are inconsistent with Ohiokha and Akhalumeh (2013) which assert that professionalism has an important role to audit performance of public companies both nationally and internationally.

The Effect of Human Resource Auditors Competence on Internal Auditors Performance

The study findings revealed that human resource auditors competence does not have significant effect on improvement of internal auditors performance. This result is consistent with Fikri (2016) that application of government accounting standards, apparatus competence, and internal audit role do not have significant effect on quality of financial statement information at regional inspectorate. Furthermore, Anak Agung Ngurah Bagus Dhermawan (2012) show that competence and motivation has no significant effect on the performance of Public Works Department employees.

These findings are inconsistent with results of Nuryanto and Afiah (2013), where auditors competence has a positive and significant effect on quality of financial statements in government work units. Octavia and Widodo (2015) corroborate Nuryanto and Afiah's findings that competence determines the level of audit quality of auditors. The basic principle of attribution theory explains that to describe a person's behaviour can be through internal



attributes (dispositional characteristics) or external attributes (environmental characteristics) (Heider, 1944); (Luthans, 2005). Attribution theory explains that past behaviour (experience) becomes the material of their evaluation to behave in the future (Reeder et al., 1982).

The Effect of Executive Follow Up Commitment on Auditors Performance

The research findings reveal that executive follow-up commitments contributes to improve internal auditors performance. Several previous studies have similarities with these findings. Achyarsyah (2015) have shown that organisational commitment of a public accounting firm has significant positive effects in implementation of independent audits of financial statements. Nasrabadi and Arbabian (2015) explained commitment has a positive and meaningful relationship on audit quality.

The effect of executive follow-up commitment on auditors performance is supported by results of respondents' answers based on indicators of executives follow-up commitment. The attitude indicator shows that auditors regularly attend to meetings held by BPK and BPKP to discuss audit findings, have the ability to solve every problem faced consistently, and rewards and sanctions for all employees fairly.

The Effect of Auditors Human Resources Competence on Spirituality Dimension

The effect of auditors human resource competence on spirituality dimension shows that with quality improvement of auditors human resource competence will affect to increase spirituality dimension with assumption that other factors are considered constant. The coefficient value of auditors human resource competence on spirituality dimension reflects the high contribution of human resource auditors competence in determining the high dimension of auditors spirituality dimension.

Competence can explain its role, Armstrong and Baron (1998) said if the behaviour is defined as competence, it can be classified as: 1) understanding what needs to be done in the form of reason: critical reason, capability and knowledge; making work be done through achievement spirit, proactive approach, confidence, control, flexibility, interests to effectiveness, persuasion and effect; 3) bringing people with motivation, interpersonal skills, interests to results, persuasion, and effect.

Executive Follow up Commitment to Auditors Spirituality Dimensions

The effect of executive follow-up commitment on spirituality dimension shows that quality improvement of executive follow-up commitment will affect to increase spirituality dimension, with assumption that other factors are considered constant. The coefficient value



of executive follow-up commitment quality on spirituality dimension reflects the high contribution of executive follow-up commitment quality to determine the high dimension of auditors spirituality dimension.

Audits follow-up is step that must be taken by auditors after the audit report is submitted to auditee. Audit follow-up is an activity to identify and document the progress of auditee in carrying out the audit recommendations. Submission of audit reports to auditees is the final stage of field audit work and the initial stage of auditors work to monitor audit follow-ups by auditee. The auditee management has responsible to follow up audit recommendations.

Auditor Human Resources Competence on Auditors Performance through Dimension of Auditors Spirituality

The research findings show that auditors human resources competence significantly affect auditors performance through the dimensions of auditors spirituality. This study results relevant to Ariati (2014) that auditors competence positively affect on auditors quality through spiritual intelligence. While Raharja (2014) explains that auditors competence significantly has a positive effect on audit quality. Spirituality intelligence does not moderate the effect of competence on audit quality.

The auditors human resources competence refers to characteristics of internal auditors behaviour that describes the motives, nature, self-concept, values, knowledge and skills in performing their work according to a standard. These characteristics are not seen and illustrated in behaviour in the form of attitude, but the elements of competence are knowledge, skills, and behaviour. The application of competence to auditor human resources is an effort to get internal auditors who have competitive ability through the implementation of vision, mission, values and organisational goals.

Executives Follow-Up Commitment on Auditors Performance through the Auditors Spirituality Dimension

The study findings show that executive follow-up commitments affect the direction and significance of auditors performance through the dimensions of auditors spirituality. These are consistent with Claude and Zamor's findings (2003) that managers and administrators in public and private sectors can use the spirituality dimension in workplace to improve performance. Beheshtifar and Zare (2013) explained that spirituality in workplace could lead to benefits in areas of creativity, process improvement, customer service, honesty and trust, personal fulfillment, and commitment, which ultimately will lead to performance improvement.



Auditors Spirituality Dimension on Auditor Performance

A study findings show that spirituality dimensions have a significant effect on auditors performance. The direct effect of auditor spirituality dimension on auditors performance is stronger than the indirect effect (through the auditors human resource competence and executive follow-up commitment). Similar studies have also found a positive and significant correlation between spirituality and job satisfaction (Usman & Denish, 2010), personal spirituality and organisational spirituality and job satisfaction (Van der Walt, 2007), workplace spirituality and job satisfaction (Eas in Yusof, 2011), spiritualist and OCB (Harmer, 2007), and individual spirituality and job satisfaction (Komala and Ganesh, 2007).

Spiritual theory explains that existential dimension focuses on purpose and meaning of life, while the religious dimension is more focused on one's relationship with God Almighty. Spiritual as a two-dimensional concept, vertical dimension as a relationship with God or the Supreme Being guides one's life, while the horizontal dimension is the relationship with oneself, with others and environment. There is an ongoing relationship between the two dimensions (Kozier, Erb, Blais & Wilkinson, 1995).

Conclusion and Recommendations

Based the results and discussion of this research, we can conclude that executive follow up commitment has significant effect to improve the internal auditors performance. Empowerment and flexibility should be followed by strong supervision and control and effective checks. Auditors human resources competence significantly affect the auditors performance through the dimensions of auditors spirituality. Higher auditors human resources competence will affect to improve auditors performance through spirituality intelligence and inner peace in work. Executive follow up commitment has a positive and significant effect on auditors performance through auditors spirituality dimensions. The executive follow-up commitments and auditors spirituality dimensions are interrelated to achieve auditors performance improvement. Professionalism of internal auditors does not affect on high internal auditors performance, so the first hypothesis is rejected. This is an indication of low professionalism of internal auditors caused by individual auditors and also from organisation. The internal auditors human resource competence can improve the dimension of auditors spirituality. The internal auditors competence who work optimally will affect the auditors spirituality dimension and encourage the happiness of auditors through the understanding of spiritual values. Executive follow up commitment has a positive and significant effect on the spirituality dimension. Implementation of executive follow-up commitment with ethical values, religion and morality orientation will increase the spirituality dimension. The auditors human resource competence does not contribute significantly to improve internal auditors performance. Therefore, the second hypothesis is rejected based on statistical test results.



This condition is caused by dimension of liability unable to improve auditors performance especially the training factor followed by auditors. The spirituality dimension plays an important role to improve the auditors performance. The quality of spirituality dimension, especially existential critical thinking and meaningfulness work indicators become a dominant part that is able to improve auditors performance.

This study has several limitations. The proposed model to increase the auditors performance is limited to auditors professionalism, internal auditors human resource competence, executive follow-up commitment, and auditors spirituality dimension. Future research should include other variables to support the auditors performance, for examples data processing systems (IT) and budget to improve auditors performance. This study is also only related to analysis at the individual level of internal auditors and has not seen comprehensively all the performance of external auditors. Therefore, future research should do research comprehensively.

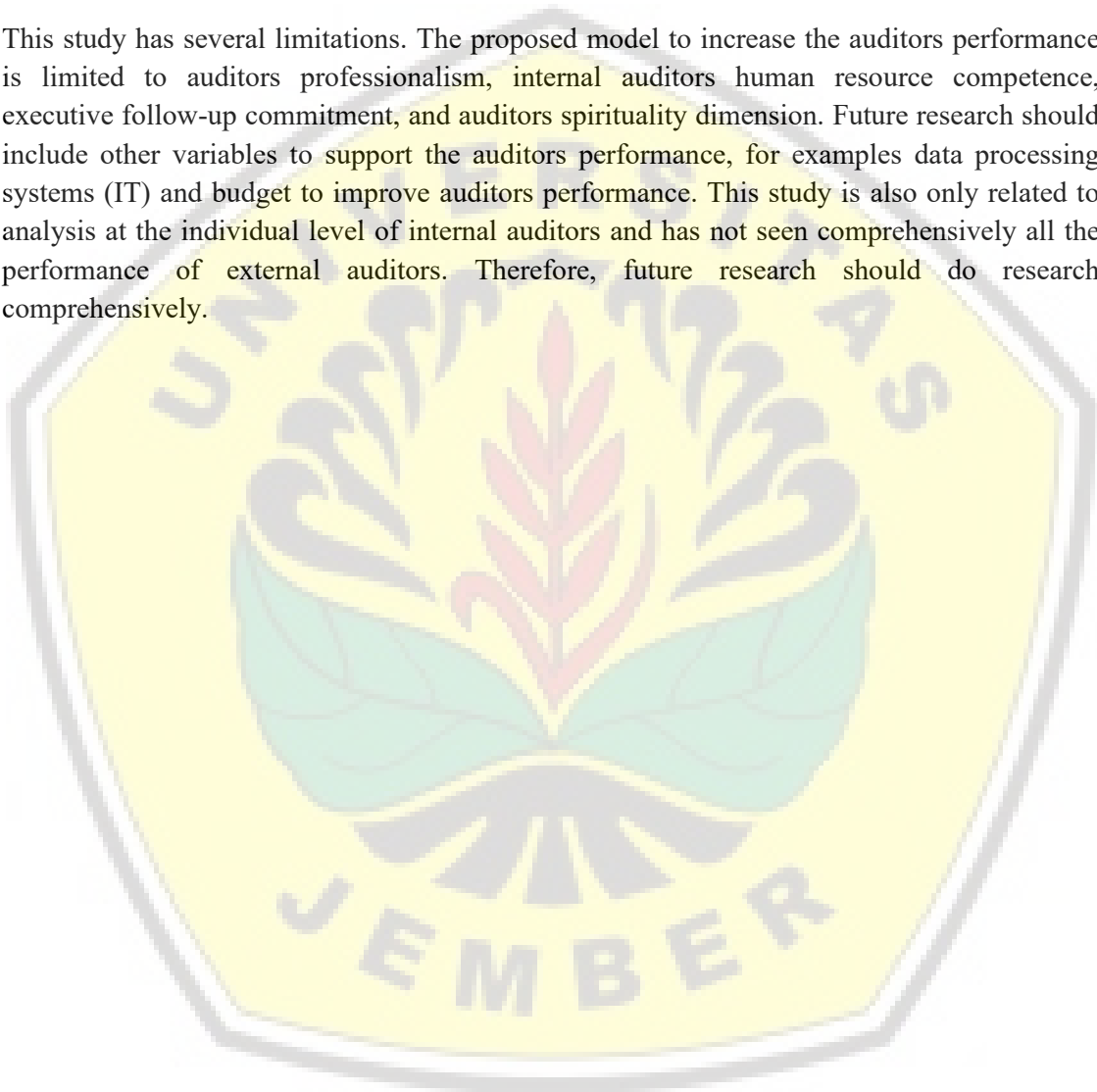



REFERENCES

- Abdolmohammadi, M.J. (2012). Chief audit executives' assessment of internal auditors' performance attributes by professional rank and cultural cluster. *American Accounting Association. Vol. 24, Iss 1.*
- Achyarsyah, P. (2015). Organizational Commitment of Public Accounting Firm, Implementation of an Independent audit of the financial statements and audit quality. *Research Journal of Finance and Accounting. Vol. 6, No. 14.*
- Akhmad Riduwan. (2012). Pengaruh Pengalaman Kerja, Independensi, dan Kompetensi Terhadap Kualitas Pemeriksaan dengan Kepatuhan Etika Auditor sebagai Variabel Pemoderasi. *Jurnal Ilmu dan Riset Akuntansi Vol. 1 No. 12.*
- Amstrong, Michael, and Barron, A. (1998). Performance Management: The New Realities. Institute of Personal and Development, New York.
- Anak Agung Ngurah Bagus Dhermawan. (2012). Pengaruh Motivasi, Lingkungan Kerja, Kompetensi, dan Kompensasi Terhadap Kepuasan Kerja dan Kinerja Pegawai Di Lingkungan Kantor Dinas Pekerjaan Umum Provinsi Bali. *Jurnal Manajemen, Strategi Bisnis, dan Kewirausahaan, Vo. 6. Nomor 2.*
- Ariati K, K. (2014). *Pengaruh kompetensi auditor terhadap kualitas audit dengan kecerdasan spiritual sebagai variabel moderating (studi persepsi auditor pada badan pengawasan keuangan dan pembangunan Provinsi Jawa Tengah).* Universitas Ekonomika dan Bisnis. Universitas Diponegoro.
- Beheshtifar, M., Zare, Elham. (2013). Effect of Spirituality in workplace on Job Performance. *Interdisciplinary Journal of Contemporary Research in Business. Vol. 5, No. 2.*
- Birkett, Bill, Barbara, Maria, Leithhead Barry, Lower Marian and Roebuck Peter, (1977). "Global Competency Framework for Internal Auditing Project", Third Draft Report. *The Institute of Internal Auditors.*
- Boyt, Thomas E, Robert F, dan Gillian Naylor. (2001), "The Role of Professionalism in Determining Job Satisfaction in Profesional Services", *Journal of Service Research, Vol.3, No.4, pp.321-330*
- Brazel, J.F., Agoglia, C.P., Hatfield, R.C. (2004). Electronic versus face-to-face review: The effects of alternative forms of review on auditors' performance. *The Accounting Review. Vol. 79, No. 4.*



- Campuzano, Lydia Guadalupe; Seteroff, Sviatoslav Steve (2009) a New Approach to a Spiritual Business Organization and Employee Satisfaction, Eastern Academy of Management.
- Claude, J., Zamor, G. (2003). Workplace spiritual and organizational performance. *Public Administration Review*. Vol. 63. Issue. 3.
- Darwanis, Mahyani, D. D., (2009). Pengaruh Kapasitas Sumber Daya Manusia, Pemanfaatan Teknologi Informasi dan Pengendalian Intrn Akuntansi terhadap Keterandalan Pelaporan Keuangan Pemerintah Daerah, *Jurnal Telaah dan Riset Akuntansi*, Vol. 2. No. 2 Juli 2009, hal. 133-151.
- Davis, K dan Newstroom John. W. (1985). Human Behavior at Work : *Organizational Behavior*. Seven Edition Mc. Grow-Hill, Inc.
- Fikri, Ali, B. M., RR. Sri Pancawati Matiningish. (2016). Pengaruh Penerapan Standar Akuntansi Pemerintah, Kompetensi Aparatur, dan Peran Audit Internal Terhadap Kualitas Informasi Laporan Keuangan. *Jurnal Ilmiah Akuntans*. Volume 9. Page 27 - 42.
- Funnell, W. (1997). The curse of Sisyphus: public sector audit independence in an age of economic rationalism. *Australian Journal of Public Administration*. 56 (4).
- Garcia-Zamor, J. (2003). Workplace Spirituality and Organizational Performance, *Public Administration Review*. Vol. 63 (3) pp. 355-363.
- Guy, Dan M., Alderman, C. Wayne dan Winters, Alan J. (2002). *Auditing*: Jilid 1. Jakarta: Erlangga.
- Hall, R, (1968). "Profesionalization and Bureaucratation". *American Sociological Review* 33: PP.92 – 104.
- Harmer, R. (2007). Organizational citizenship behavior, emotional intelligence and spirituality: What's the relationship? Prepared for 7th Industrial and Organizational Psychology Conference (IOP) of the APS/1st Asia Pacific Congress on Work and Organizational Psychology (APCWOP), (Un-published manuscripts).
- Heider, F. (1944). Social perception and phenomenal causality. *Psychological Review*. Vol. 51, pp: 358-374.
- Herliansyah dan Meifida Ilyas. (2006). Pengaruh Pengalaman Auditor terhadap Pengalaman Bukti Tidak Relevan dalam Audit Judgment. Simposium Nasional Akuntansi IX. Padang.



- I Gede Bandar Wira Putra. (2013). Pengaruh Independensi, Profesionalisme, Struktur Audit, dan Role Stress Terhadap Kinerja Auditor BPK RI Perwakilan Provinsi Bali. Tesis. FE Universitas Udayana Bali.
- Janfeshan, K. B. Panahy, M. Veiseh, F. Kamari,. (2011). Spirituality in Working Environment and its impacts on the Efficiency of Management. International Conference on Business and Research (2nd ICBER 2011) Proceeding. Malaysia.
- Kalbers, Lawrence P. dan Fogarty, Timothy J. (1995). Professionalism and Its Consequences: A Study of Internal Auditors, *Auditing: A Journal of Practice and Theory*, 14: 64-86.
- Kinjerski, Val; Skrypnek, Berna J. (2006). Creating organizational conditions that foster employee spirit at work. *Leadership & Organization Development Journal* Vol. 27, No. 4, pp 280-295.
- Komala, K. And Ganesh (2007). Individual spirituality at work and its relationship with job satisfaction and burnout: an exploratory study among healthcare professionals, *The Business Review*, Vol.7 No. 1, pp124-129.
- Kozier, Erb, Blais, and Wilkinson. (1995). *Fundamental of Nursing Concept Proses and Practise*. California: Addison-Wesley Publishing Company. Inc
- Leewu, F.L. (1992). Performance auditing and policy evaluation: Discussing similarities and dissimilarities. *The Canadian Journal of Program Evaluation*. Vol. 7, No. 1.
- Luthans, F. (2005). *Organizational Behavior*, 6th edition. Singapura; Mc Graw Hill International Editions, P. 144-146
- Milliman, J., Czaplewski, A. J. And Ferguson, J. (2003). Workplace spirituality and employee work attitudes. An exploratory empirical assessment. *Journal of Organizational Change Management*. Vol. 16 (4), pp. 426-447.
- Mitroff, I. I., and Denton, E. A. (1999a). A study of spirituality in the workplace. *Sloan Management Review*, Vol. 40; p. 83-92.
- Nasrabadi, A., Arbabian, A. (2015). The effect of professional ethics and commitment on audit quality. *Management Science Letters* (5)
- Novyarni, N. (2014). Influence of internal auditor competence and independence on the quality of financial reporting by municipal/provincial government. *International Journal of Economics, Commerce and Management*. Vol. II, Iss. 10.



- Nuryanto, M. dan Afiah, N.N., (2013). The Impact of Apparatus Competence, Information Technology Utilization and Internal Control on Financial Statement Quality. *World Review of Business Research*, Vol. 3. No. November 2013 Issue Pp. 157-171.
- Obert, S., Munyunguma, I.N. (2014). Internal audit perceptions and their impact on performance of the internal audit function. *IOSR Journal of Business and Management (IOSR-JBM)*. Vol. 16, Iss. 5.
- Octavia, E., Widodo, N.R. (2015). The effect of competence and independence of auditors on the audit quality. *Research Journal of Finance and Accounting*. Vol. 6, No. 3.
- Ohiokha, F.I., dan Akhalumeh, P.B. (2013). Auditing standards and auditors performance: The Nigerian Experience. *European Journal of Accounting Auditing and Finance Research*. Vol. 1. No. 3.
- Raharja, K.A.K. (2014). Pengaruh kompetensi auditor terhadap kualitas audit dengan kecerdasan spiritual sebagai variabel moderating (Studi persepsi auditor pada badan pengawasan keuangan dan pembangunan Provinsi Jawa Tengah). *Diponegoro Journal of Accounting*. Vol. 3, No. 3.
- Rahmawati. (1997). Hubungan antara Profesionalisme Internal Auditor dengan Kinerja, Kepuasan Kerja, Komitmen dan Keinginan Untuk Pindah. *Tesis Program Pasca Sarjana UGM* (Tidak dipublikasikan)
- Reeder, G.D., Hendeerson, D.J., Sullivan, J.J. (1982). From dispositions to behaviors: The flip side of attribution. *Journal of Research in Personality*. Vol. 16 (3), pp: 355-375.
- Robbins, P. Stephen. (2003). *Organization Behaviour : Concept, Controversies, Applications*. Seventh Edition. Prentice Hall Inc.
- Robbins, Stephen P dan Timothy A. Judge. (2008). *Perilaku Organisasi: Organizational Behaviour*. Edisi 12. Jakarta : Salemba Empat. Buku 1.
- Sawyer. (2003), Internal Auditing, *The Practice of Modern Internal Auditing*. 5th Edition, Florida, The Institute of Internal Auditors.
- Schroeder, R dan Imdieke. (1977). Local Cosmopolitan And Bureaucratic Perception In Public Accounting Firms. *Accounting, Organization and Society* 2 : 39-46
- Shafer, Willian E and Jane Park, L. and Liao, Woody M. (2002). Professionalism, Organizational-Professional Conflict and Work Outcomes". *Accounting, Auditing, and Accounting Journal*, Volume 15 No. 1 pp. 46-68



- Silviana., Zahara, G. (2015). The influence of competence local government agencies and the implementation government of internal control system toward the quality of local government financial statement. *Research Journal of Finance and Accounting*. Vol. 6, No. 11.
- Sinnott, G.C., Madison, G.H. and Pataki, G.E. (2002). Competencies: Report of the Competencies Workgroup, *Workforce and Succession Planning Workgroups*. New York State Governor's Office of Employee Relations and the Department of Civil Service.
- Tugiman, H. (2000). *Pengaruh Peran Auditor Internal serta Faktor Pendukungnya Terhadap Peningkatan Pengendalian Internal dan Kinerja Perusahaan (Survei pada 102 BUMN dan BUMD di Indonesia)*. Disertasi Unpad, Bandung.
- Usman dan Danish. (2010). Spiritual Consicousness in Banking Managers and its Impact on Job Satisfaction. *International Business Research*. Vol. 3, No. 2
- Van der Walt, F. (2007). *The relationship between spirituality and job satisfaction*. Dissertation, University of Pretoria, South Africa.
- Yusof Juhaizi Mohd. (2011). A Multidimensional Approach in the Relationship between Spiritual Leadership and Job Satisfaction : A Conceptual Frame Work, Proceedings of 2nd Internasional Conference on Business and Economic Research, 2461-2479
- Zohar, D. I Marshall. (2000). SQ (Spritual Intelligence) : The Ultimate Intelligence, Mizam. Media Utama, Bandung.
- Zureigat, Q.M., dan Al-Moshaigeh, A. (2014). Measuring the performance of internal audit function in Saudi listed companies: An empirical study. *International Business Research*. Vol. 7, No. 7.